

Beta *Action* 2026



VALID UNTIL 28/02/2027

Beta

RSC 50 2.0



Design your workshop

ONLINE CONFIGURATOR

Simple, fast and intuitive



WORKSHOP EQUIPMENT C45PRO 2.0 - RCS50 2.0	
2÷7	
CONTAINERS	
8÷12	
ASSORTMENT AND THERMOFORMED TRAYS	
13÷16	
WORKBENCHES	
17-18	
TROLLEYS AND LIFTING	
12-18-19	
TOOL CHESTS, BAGS AND CASES	
20÷23	
WRENCHES	
24÷28	
COLOUR CODE	
29	
SCREWDRIVERS	
30-31	
SOCKETS	
32÷35	
TORQUE WRENCHES	
36÷39	
PLIERS	
40÷42	
HAMMERS AND CHISELS	
43	
DRILLING AND THREADING TOOLS	
44	
POWER TOOLS	
45	
PLUMBING TOOLS	
46	
GENERAL MAINTENANCE	
46-47	

LIGHTING	
48÷51	
ELECTRICAL PRODUCTS	
52-53	
MEASURING TOOLS	
53-54	
ELECTROTECHNICS	
54	
CUTTING TOOLS	
55÷57	
1000V INSULATED TOOLS	
57÷60	
INOX	
61	
REELS	
62-63	
PULLERS	
64	
AUTOMOTIVE	
65÷85	
ROBUR	
85	
AUTOMOTIVE KIT - TIRE KIT	
86-87	
PNEUMATIC TOOLS	
88÷93	
SAFETY FOOTWEAR	
94÷99	
WORKWEAR	
100÷104	
BETA COLLECTION	
105	
Blister pack support	

The images are for reference only. Beta Utensili S.p.A. reserves the right to update and upgrade its product range without notice.

NEW

PURCHASE THE WORKSHOP EQUIPMENT COMBINATION, **C45PRO**

46-cm-DEEP WORKTOP WORKSHOP EQUIPMENT COMBINATION **C45PRO**

C45PRO X/196UT

305 kg

045001987

Workshop equipment combination C45PRO comprising the following:

- Stainless steel coated MDF worktop, dimensions 2,040x463 mm (C45PX/3-2.0MT)
- Fixed module with 7 drawers (C45PRO M7)
- Mobile roller cab with 7 drawers (C45PRO C7)
- Fixed service module (C45PRO MS)
- 3 perforated tool panels (C45PRO PF)
- 3 wall-mounted cabinets (C45PRO PM)
- 3 wall brackets, wide type (C45PRO SL)
- 1 wall bracket, narrow type (C45PRO SS)
- Two-door cabinet (C45PRO AS2)

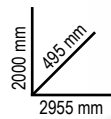

ASSORTMENT OF **196** TOOLS



MMC45-V1 BW



MMC45-V2N BW



14"
12"



MMC45-V3 BW



PROMO

NEW

COMPLETE WITH ASSORTMENT THAT BEST CATERS TO YOUR NEEDS!

61.5-cm-DEEP WORKTOP WORKSHOP EQUIPMENT COMBINATION C45PRO 2.0

C45PRO 2.0 X/268UT

334 kg **045009158**

- **Stainless steel coated MDF** worktop, dimensions 2,040x**615** mm (C45PRO 2.0 PXE/3-2.0MT)

C45PRO 2.0 W/268UT

318 kg **045009159**

- **Multi-ply wood** worktop, dimensions 2,040x**615** mm (C45PRO 2.0 PWE/3-2.0MT)

Workshop equipment combination C45PRO 2.0 comprising the following:

- Fixed module with 7 drawers (C45PRO 2.0 M7)
- Mobile roller cab with 7 drawers (C45PRO 2.0 C7)
- Fixed service module (C45PRO 2.0 MS)
- 3 perforated tool panels (C45PRO 2.0 PF)
- 3 wall-mounted cabinets (C45PRO 2.0 PM)
- 3 wall brackets, wide type (C45PRO 2.0 SL)
- 1 wall bracket, narrow type (C45PRO 2.0 SS)
- Two-door cabinet (C45PRO 2.0 AS2)

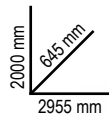

ASSORTMENT OF 268 TOOLS



MM-1 BW



MM-2 BW



MM-3 BW

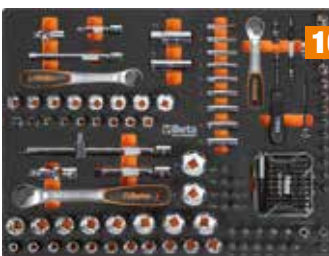

MM-4/N BW



MM-5 BW



BETA'S NEW RATCHET



PROMO

NEW

PURCHASE THE WORKSHOP EQUIPMENT COMBINATION, C45PRO 2.0

61.5-cm-DEEP WORKTOP

C45PRO 2.0 B7X/196UT

211 kg 045009155

- Stainless steel coated MDF worktop, dimensions 1,360x615 mm (C45PRO 2.0 PXE/2-1.3MT)

C45PRO 2.0 B7W/196UT

201 kg 045009156

- Multi-ply wood worktop, dimensions 1,360x615 mm (C45PRO 2.0 PWE/2-1.3MT)

Workshop equipment combination C45PRO 2.0 comprising the following:

- Fixed module with 7 drawers (C45PRO 2.0 M7)
- Fixed two-door module (C45PRO 2.0 MA)
- 2 wall-mounted cabinets (C45PRO 2.0 PM)
- 2 perforated tool panels (C45PRO 2.0 PF)
- 2 wall brackets, wide type (C45PRO 2.0 SL)
- 1 wall bracket, narrow type (C45PRO 2.0 SS)
- Single-door cabinet (C45PRO 2.0 AS1)

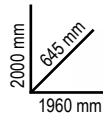

ASSORTMENT OF 196 TOOLS



MMC45-V1 BW



MMC45-V2N BW



BETA'S NEW RATCHET

14"
12"



MMC45-V3 BW



PROMO

NEW

COMPLETE WITH ASSORTMENT THAT BEST CATERS TO YOUR NEEDS!

61.5-cm-DEEP WORKTOP

C45PRO 2.0 AX/157UT

📦 234,5 kg 📄 045009167



- Stainless steel coated MDF worktop, dimensions 2,040x615 mm (C45PRO 2.0 PXE/3-2.0MT)

C45PRO 2.0 AW/157UT

📦 219 kg 📄 045009168



- Multi-ply wood worktop, dimensions 2,040x615 mm (C45PRO 2.0 PWE/3-2.0MT)

Workshop equipment combination C45PRO 2.0 comprising the following:

- Fixed service module (C45PRO 2.0 MS)
- Fixed module with 7 drawers (C45PRO 2.0 M7)
- Fixed two-door module (C45PRO 2.0 MA)
- 3 wall-mounted cabinets (C45PRO 2.0 PM)
- 3 perforated tool panels (C45PRO 2.0 PF)
- 2 wall brackets, narrow type (C45PRO 2.0 SS)
- 2 wall brackets, wide type (C45PRO 2.0 SL)

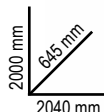

ASSORTMENT OF 157 TOOLS



FIXED ACCESSORIES INCLUDED



PROMO

NEW

PURCHASE THE WORKSHOP EQUIPMENT COMBINATION, RSC50 2.0

70-cm-DEEP WORKTOP

RSC50 2.0 D/224UT

276 kg 050001090

- Worktop 1,495x700 mm made from **sheet metal** (RSC50 2.0 NPG/2-1.5MT)

RSC50 2.0 DX/224UT

275 kg 050001080

- Worktop 1,495x700 mm made from **stainless steel coated MDF** (RSC50 2.0 PX/2-1.5MT)

RSC50 2.0 DW/224UT

263 kg 050001081

- Worktop 1,495x700 mm made from **multi-ply wood** (RSC50 2.0 PW/2-1.5MT)

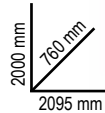

Workshop equipment combination RSC50 2.0 comprising the following:

- 1 fixed module with 7 drawers (RSC50 2.0 M7)
- 1 fixed two-door module (RSC50 2.0 MA)
- 2 wall-mounted cabinets (RSC50 2.0 PM)
- 2 upper perforated tool panels (RSC50 2.0 PFS)
- 2 lower perforated tool panels (RSC50 2.0 PF)
- 2 pairs of right/left uprights (RSC50 2.0 P/2MDX-SX)
- 1 single-door cabinet (RSC50 2.0 A1)



ASSORTMENT OF 224 TOOLS



M391



M392



M394MH

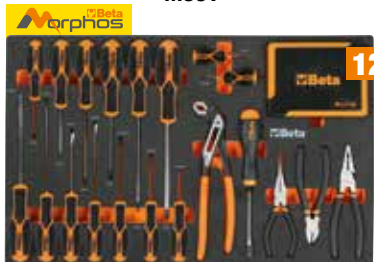

M397MH



PROMO

NEW

COMPLETE WITH ASSORTMENT THAT BEST CATERS TO YOUR NEEDS!

70-cm-DEEP WORKTOP

RSC50 2.0 F/411UT

411 kg **050001095**

- Worktop 2,240x700 mm made from sheet metal (RSC50 2.0 NPG/3-2.2MT)

RSC50 2.0 FX/411UT

405 kg **050001097**

- Worktop 2,240x700 mm made from stainless steel coated MDF (RSC50 2.0 PX/3-2.2MT)

RSC50 2.0 FW/411UT

386 kg **050001098**

- Worktop 2,240x700 mm made from multi-ply wood (RSC50 2.0 PW/3-2.2MT)

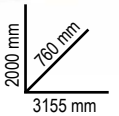

Workshop equipment combination RSC50 2.0 comprising the following:

- 1 fixed module with 7 drawers (RSC50 2.0 M7)
- 1 mobile roller cab with 7 drawers (RSC50 2.0 C7)
- 1 fixed service module with 2 drawers (RSC50 2.0 MS-2C)
- 3 wall-mounted cabinets (RSC50 2.0 PM)
- 3 upper perforated tool panels (RSC50 2.0 PFS)
- 3 lower perforated tool panels (RSC50 2.0 PFI)
- 3 pairs of right/left uprights (RSC50 2.0 P/2MDX-SX)
- 1 two-door cabinet (RSC50 2.0 A2)



ASSORTMENT OF 411 TOOLS



40

M25



116

M105MH

1/4" 3/8" 1/2"



13

M169



62

M245MH



34

M238



146

M320



IMPACT DRILL 20V 1972/K20V-13BMC



PROMO

RSC RANGE

THE EVOLUTION OF PERFECTION



RSC24

Mobile Roller cab, empty

- ABS reinforced worktop
- Multi-purpose top with anti-fall edges and eight holes for accommodating screwdrivers
- 4 castors Ø 125 mm: 2 fixed and 2 steering (one with brake)
- Front centralized safety lock
- Built-in bottle holder (can be applied on both sides).
- Drawer bases protected by foamed rubber mats
- **Each drawer can accommodate up to 4 EVA foam or ABS thermoformed trays**



	kg	Ral 2011 Ral 7016	Ral 3000 Ral 7016	Ral 7016	Ral 2011	Ral 9006 Ral 7016	Ral 5015 Ral 7016	Ral 9005
RSC24/7	63	024004071	024004073	024004077	024004070	024004072	024004076	024004079
RSC24/5	60	024004051	024004053	024004057				
RSC24/6	62	024004061	024004063	024004067				
RSC24/8	66	024004081	024004083	024004087				

RSC24/7		
n°	mm	kg Max
5	70 mm	25 kg
1	140 mm	30 kg
1	210 mm	30 kg

RSC24/5		
n°	mm	kg Max
2	70 mm	25 kg
2	140 mm	30 kg
1	280 mm	35 kg

RSC24/6		
n°	mm	kg Max
4	70 mm	25 kg
1	140 mm	30 kg
1	280 mm	35 kg

RSC24/8		
n°	mm	kg Max
6	70 mm	25 kg
2	140 mm	30 kg

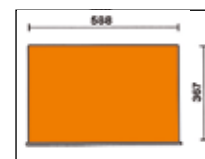

2400 RSC24/KA4

024004884

Kit of accessories for mobile roller cabs RSC24, RSC24A and RSC51

Composed by:

- Perforated tool panel **2400 RSC24/PF**
- Folding shelf **2400 RSC24/MP**
- Document holder **2400 RSC24/PD-A**
- Paper roll holder **2400 RSC24/PC-A**



NEW

PURCHASE THE ASSORTMENT THAT BEST CATERES TO YOUR NEEDS

THE ROLLER CAB RSC24 IS INCLUDED IN THE PRICE!



2400 RSC24/7-VAS

Assortment of **223** tools for AUTOMOTIVE Maintenance **1/4" 1/2"**

Medium version



M301



M304



M306MH



M311MH



INCLUDED:
Mobile roller cab RSC24/7



2400
RSC24/7-VAS/FO
024004048

NEW



2400
RSC24/7-VAS/A
024004043

2400 RSC24/8-VAL

Assortment of **445** tools for AUTOMOTIVE Maintenance **1/4" 3/8" 1/2"**

Extra large version



M25



M304



M118



REVERSIBLE
IMPACT WRENCH
1927P



M105MH



M158MH

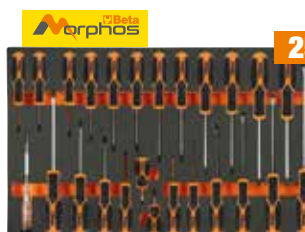

M195MH



M266

**THE MOST COMPLETE
BETA ASSORTMENT EVER**



INCLUDED:
Mobile roller cab RSC24/8



2400
RSC24/8-VAL/O
024004007

NEW



2400
RSC24/8-VAL/A
024004026

RSC24AXLP/7

105 kg

Mobile roller cab with 7 drawers, with wood worktop and ANTI-TILT SYSTEM, long model, empty

- Long model with 7 fully removable drawers (882x367 mm), with ball bearing slides
- Multi-ply wood worktop with holes for a vice 1599F/100 or 1599GI/100 (to be ordered separately)
- Sturdy nylon front, with built-in label holder
- Drawer bases protected by foamed rubber mats
- 4 castors, Ø 125 mm: 2 fixed and 2 steering (one with brake)
- Front centralized safety lock
- Built-in side bottle holder (can be applied on both sides)
- Built-in paper roll holder
- **Each drawer can accommodate up to 6 EVA foam or ABS thermoformed trays**

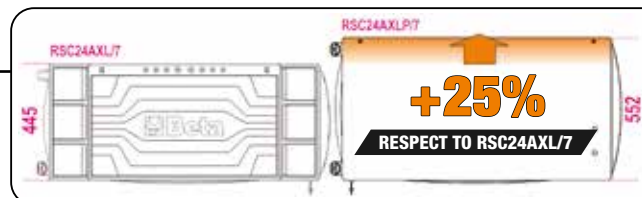

n°	Max
5	70 mm
1	140 mm
1	210 mm



Ral 2011	Ral 3000	Ral 7016
Ral 7016	Ral 7016	Ral 7016
024004571	024004573	024004577

RSC24L-CAB

82 kg

Mobile roller cab with 7 drawers and TOOL CABINET

- 7 drawers (588x367 mm) with ball bearing slides:
 - 5 drawers, 70 mm high
 - 1 drawer, 140 mm high
 - 1 drawer, 210 mm high
- Drawer bases protected by foamed rubber mats
- 4 castors, Ø 125 mm: 2 fixed and 2 steering with brakes
- Front centralized lock
- **Side tool cabinet with lockable door and vertically adjustable interior shelf**
- Multi-ply wood worktop with holes for a vice (1599F/100, to be ordered separately)
- Built-in paper roll holder
- Double rear bottle holder
- Built-in side bottle holder



Ral 2011	Ral 3000	Ral 7016
Ral 7016	Ral 7016	Ral 7016
024004471	024004473	024004477

n°	Max
5	70 mm
1	140 mm
1	210 mm



RSC24AXL

Mobile roller cab, WITH ANTI-TILT SYSTEM, long model

- New ABS reinforced worktop with anti-fall edges, eight holes for accommodating screwdrivers and 6 tote trays
- **Sturdy nylon front, with built-in label holder**
- Drawer bases protected by foamed rubber mats
- 4 castors, Ø 125 mm: 2 fixed and 2 steering (one with brake)
- Front centralized safety lock
- Built-in side bottle holder (can be applied on both sides)
- **Each drawer can accommodate up to 6 EVA foam or ABS thermoformed trays**

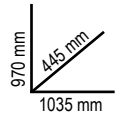

	Ral 2011 Ral 7016	Ral 3000 Ral 7016	Ral 7016	n°	↓ max	kg
RSC24AXL/7	024004271	024004273	024004277	5	70 mm	30 kg
				1	140 mm	35 kg
				1	210 mm	35 kg
RSC24AXL/8	024004281	024004283	024004287	6	70 mm	30 kg
				2	140 mm	35 kg
RSC24AXL/9	024004291	024004293	024004297	8	70 mm	30 kg
				1	140 mm	35 kg

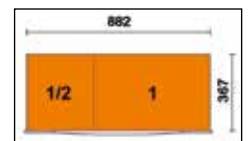

RSC24AXXL

Mobile roller cab with 8 drawers and anti-tilt system, long model

- 1 fully removable drawer (1,176x367 mm), with ball bearing slides
- 7 fully removable drawers (882x367 mm), with ball bearing slides:
 - 6 drawers 70 mm high
 - 1 drawer 140 mm high
- **Worktop made from stainless steel coated MDF**, with holes for vice item 1599F/125 or 1599GI/125 (to be ordered separately) and 6 tote trays
- Sturdy nylon fronts, with built-in label holders
- Drawer bases protected by foamed rubber mats
- Removable side compartment, with ball bearing slides, with shelf and lock
- 4 castors, Ø 150 mm: 2 fixed and 2 steering with brakes
- 3 safety locks
- Built-in paper roll holder
- Built-in bottle holder
- Following trays can be added: **up to 8 EVA foam or ABS thermoformed trays in drawer 1,176x367 mm**
up to 6 EVA foam or ABS thermoformed trays in drawer 882x367 mm

YOUR WORKSHOP ON WHEELS



Ral 2011 Ral 7016	Ral 3000 Ral 7016	Ral 7016
024004781	024004783	024004787

n°	↓ Max	kg
1	70 mm (1.176x367 mm)	40 kg
6	70 mm (882x367 mm)	30 kg
1	140 mm (882x367 mm)	35 kg

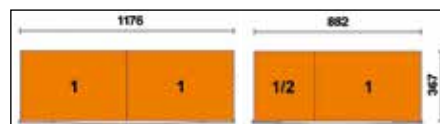

RSC28

SuperTank trolley with wood worktop and 10 drawers

- 10 drawers (588x367 mm) with ball bearing slides
- Quick, safe system for opening and closing drawers, with nylon and fibreglass front
- Drawer bases protected by foamed rubber mats
- 4 high-capacity castors, Ø 150 mm: 2 fixed and 2 steering with brakes
- 2 centralized safety locks
- Multi-ply wood worktop with holes for a vice (1599F/150 - 1599GI/150, to be ordered separately)
- 4 bottle holders (2 front and 2 rear)
- 6 side tote trays
- Side compartment with foldaway door with lock
- 135-mm-high storage compartment with plastic-covered base

kg
1200

kg
130



Ral 2011	Ral 3000	Ral 7016
Ral 7016	Ral 7016	Ral 7016
028003001	028003003	028003007

n°	mm	Max
8	70 mm	25 kg
2	210 mm	30 kg



- 5 side drawers:**
- 4 drawers, 70 mm high
 - 1 drawer, 210 mm high
- 5 front drawers:**
- 4 drawers, 70 mm high
 - 1 drawer, 210 mm high

RSC51

Service tool trolley with 3 drawers

- ABS reinforced worktop with anti-fall edges and 8 holes for accommodating screwdrivers
- 3 drawers (588x367 mm) with ball bearing slides, 70 mm high
- Each drawer can accommodate up to 4 EVA foam or ABS thermoformed trays
- Front centralized safety lock
- Convenient side screwdriver holder included
- 4 castors, Ø 125 mm: 2 fixed castors and 2 swivel castors (one with brake)

kg
38



kg
400

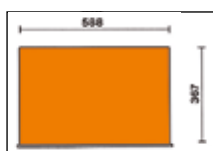

n°	mm	Max
3	70 mm	15 kg

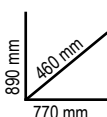

Ral 2011	Ral 3000	Ral 7016
Ral 7016	Ral 7016	Ral 7016
051000300	051000303	051000307

C275

Folding tool trolley for outdoor jobs, made from sheet metal

- 2 drawers, 588x277 mm, with ball bearing slides, for two-way opening
- Large lower object compartment, 588x277x220 mm
- 2 fixed castors, Ø 160 mm, and 2 steering castors with brake, Ø 100 mm
- Thermoplastic worktop with 6 built-in tool trays
- Centralized lock
- Can accommodate drawer partitions and MC foam tool trays

kg
20



n°	mm	Max
2	70 mm	20 kg



Ral 2011	Ral 3000	Ral 7016
Ral 7016	Ral 7016	Ral 7016
027000201	027000203	027000202



PATENTED

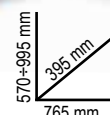

5988VU/M SOFT MODULE SYSTEM

30 kg **059880356**

Assortment of 214 tools in soft foam tray

14" 12"

Recommended with: RSC24 - RSC24A - RSC24AXL - RSC24AXLP/7 - RSC24AXXL - C37 - C39 - C39SM - C39MD - RSC28 - C59 - C58BC - RSC55 - RSC50 2.0

Quantity/Description	Beta N.	TR
22 combination wrenches 6-7-8-9-10-11-12-13-14-15-16-17-18-19-20-21-22-24-27-30-32-36 mm	42	M01
11 double open end wrenches 6x7-8x9-10x11-12x13-14x15-16x17-18x19-20x22-21x23-24x27-30x32 mm	55	M30
11 double ended offset ring wrenches 6x7-8x9-10x11-12x13-14x15-16x17-18x19-20x22-21x23-24x27-30x32 mm	90	M30
9 ball head offset hexagon key wrenches ○ 1,5-2-2,5-3-4-5-6-8-10 mm	96BPC/SC9	M30
6 screwdriver for slotted head screws ● 2,5x50-3x75-4x100-5,5x125-6,5x150-8x200 mm	1201E	M213
1 screwdriver for slotted head screws, extra-short series ● 4x30 mm	1201EN	M213
4 screwdriver for cross head Phillips® screws ● PH0x60-PH1x80-PH2x100-PH3x150 mm	1202E	M213
1 screwdriver for cross head Phillips® screws, extra-short series ● PH1x30 mm	1202EN	M213
12 screwdrivers for Torx® head screws, with handles ○ T6-T7-T8-T9-T10-T15-T20-T25-T27-T30-T40-T45	1207E/TX	M213
1 mains testing screwdriver ●	1253	M213
3 drift punches 2-3-4 mm	30	M230
6 pin punches 2-3-4-5-6-8 mm	31	M230
1 centre punch Ø 4 mm	32	M230
1 flat chisels 150 mm	34	M230
2 flat chisels, ribbed type 200-250 mm	35	M230
1 cape chisels, standard type 125 mm	36	M230
1 engineer's hammer 500 g	1370	M230
1 soft face hammer Ø 35 mm	1390	M230
1 measuring tape 3 m	1692	M230
1 telescopic magnet with flexible head	1712TF	M230
5x files 200 mm	1719BMA...Q/T/P/M/R	M230
1 steel wire brush	1737NX	M230
1 snap - off blade utility knife 18 mm	1771	M230
1 circlip pliers straight, internal ○ 180 mm	1032	M129
1 circlip pliers bent, internal ○ 170 mm	1034	M129
1 circlip pliers straight, external ● 175 mm	1036	M129
1 circlip pliers bent, external ● 175 mm	1038	M129
1 slip joint pliers 250 mm	1048N	M129
1 self - locking pliers 240 mm	1052	M129
1 diagonal cutting nippers 160 mm	1082BM	M129
1 construction worker's pincers 220 mm	1098	M129
1 compound leverage shears, straight blades 250 mm	1122	M129
1 electrician's scissors, straight blades	1128BMX	M129
1 combination pliers = 180 mm	1150BM	M129
1 extra-long needle nose pliers ● 160 mm	1166BM	M129
1 extra-long bent needle nose pliers ● 160 mm	1168BM	M129
3 sockets holder	895/1/3/6	M100MH
13 1/4" hexagon sockets ○ 4-4,5-5-5,5-6-7-8-9-10-11-12-13-14 mm	900	M100MH
9 hexagon hand sockets, long series ○ 5-6-7-8-9-10-11-12-13 mm	900L	M100MH
5 1/4" socket drivers for hexagon screws ○ 3-4-5-6-7 mm	900ME	M100MH

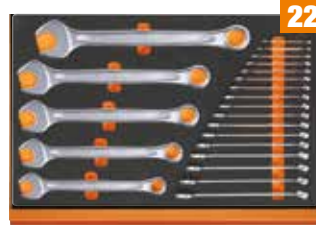

M01



M30

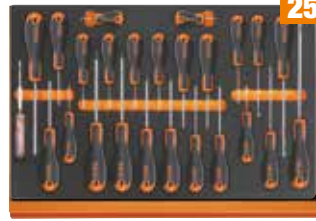

M213



M230



M129



M100MH

- 4 1/4" socket drivers for slotted head screws ● 0,8x4-1x5,5-1,2x6,5-1,2x8 mm
- 4 1/4" socket drivers for cross head Phillips® screws ● PH1-PH2-PH3-PH4
- 7 socket drivers for Torx® head screws ○ T10-T15-T20-T25-T27-T30-T40
- 1 1/4" drive extension bar 50 mm
- 1 1/4" drive extension bar 100 mm
- 1 1/4" drive extension bar 150 mm
- 1 1/4" drive universal joint
- 1 1/4" drive spinner handle
- 1 1/4" drive swivel T-handle
- 1 1/4" reversible ratchet ⊕
- 21 1/2" square drive hexagon sockets ○ 8-10-11-12-13-14-15-16-17-18-19-20-21-22-23-24-26-27-28-30-32 mm
- 1 adaptor, 1/2" female and 3/8" male drives 125 mm
- 1 1/2" drive universal joint 250 mm
- 2 angular extension bar - 1/2" 125 mm - 250 mm
- 1 1/2" drive sliding T-handle 305 mm
- 1 1/2" drive reversible ratchet ⊕
- 8 1/2" sockets for Torx® head screws ○ 10-12-14-16-18-20-22-24 mm
- 11 hexagon hand sockets ○ 10-12-13-14-15-16-17-18-19-21-22 mm

5904VU/M SOFT MODULE SYSTEM

12 kg **059041201**

Assortment of 90 tools in soft foam tray

12"

Recommended with: RSC23T - RSC24 - RSC24A - RSC24AXL - RSC24AXLP/7 - RSC24AXXL - RSC24L/7 - RSC24L - CAB - RSC28 - C37 - C39 - C39T - C39SM - C39MD - RSC51 - RSC55 - RSC50 2.0 - C59 - C58BC

Quantity/Description	Beta N.	TR
16 combination wrenches 6+21 mm	42	M05
8 double open end wrenches 6x7-8x9-10x11-12x13-14x15-16x17-18x19-20x22 mm	55	M33
9 offset hexagon key wrenches ○ 1,5-2-2,5-3-4-5-6-8-10 mm	96/SC9	M33
6 drivers for Torx® head screws ○ T8-T10-T15-T20-T25-T30	1227TX	M204MH
3 screwdrivers for slotted head screws ● 3x75 - 5,5x150 - 6,5x150 mm	1221	M180MH
3 screwdrivers for cross head Phillips® screws ● PH0x60-PH1x80-PH2x100 mm	1222	M180MH
8 offset hexagon key wrenches ○ 2-2,5-3-4-5-6-7-8 mm	96T	M50
1 1/2" wobble extension bar 125 mm	920AN/125	M83
1 1/2" wobble extension bar 250 mm	920AN/250	M83
1 1/2" drive universal joint	920/25	M83
1 1/2" drive sliding T-handle	920/42	M83
1 1/2" drive reversible ratchet ⊕	920/55	M83
19 1/2" square drive hexagon sockets ○ 10+24 - 26 - 27 - 30 - 32 mm	920A	M83
1 heavy-duty diagonal cutting nippers 160 mm	1084	M137
1 combination pliers bright chrome-plated = 180 mm	1150	M137
1 extra-long needle nose pliers ● 160 mm	1166	M137
1 slip joint pliers, slip-proof PVC coated handles 250 mm	1048N	M153
1 self - locking pliers 240 mm	1052	M153
2 flat chisels, ribbed type 100 - 200 mm	35	M234
1 engineer's hammer 300 g	1370	M234
1 soft face hammer Ø 35 mm	1390	M234
1 circlip pliers straight, internal ○ 180 mm	1032	M145
1 circlip pliers bent, internal ○ 170 mm	1034	M145
1 circlip pliers straight, external ● 175 mm	1036	M145
1 circlip pliers bent, external ● 175 mm	1038	M145



M05



M50



M137



M83

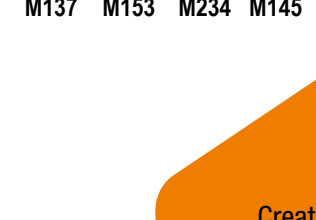

M153



M234



ONLINE CONFIGURATOR

Create your own roller cab with your favourite tools and accessories

M01

4,5 kg **02450001**

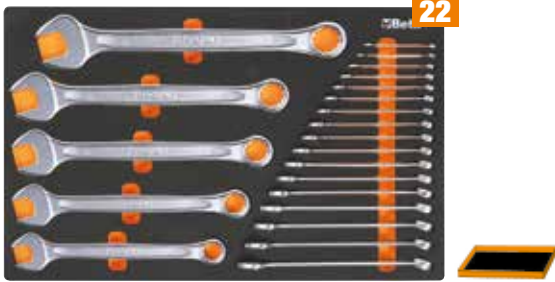

22

42 6-7-8-9-10-11-12-13-14-15-16-17-18
19-20-21-22-24-27-30-32-36 mm

M25

5,1 kg **024500025**



40

42 6-7-8-9-10-11-12-13-14-15-16-17-18-19-21-22-24-27 mm
90 6x7-8x9-10x11-12x13-14x15-16x17-18x19 mm
123Q1/4
123Q3/8
123Q1/2
142 8-9-10-11-12-13-14-15-16-17-18-19 mm

M60MH

1,9 kg **024500072**



23

○ 96T 2-2,5-3-4-5-6-7-8-10 mm
○ 97BTX/SC8 T9-T10-T15-T20-T25-T27-T30-T40 mm
○ 944MH 5-6-7-8-10-13 mm

NEW

M63

3,4 kg **024500063**



8

○ 952 7-8-10-12-13-14-17-19 mm

M100MH

6,7 kg **024500109**

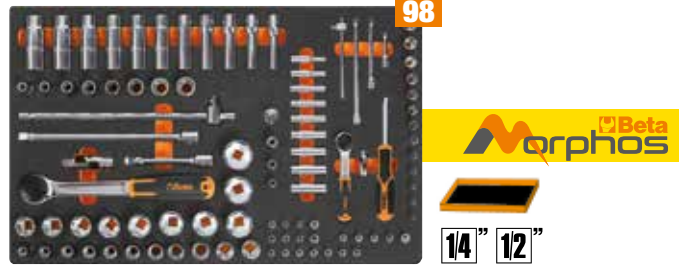

98

Beta Morphos

1/4" 12"

895/1 - 895/3 - 895/6
○ 900 4-4,5-5-5,5-6-7-8-9-10-11-12-13-14 mm
5-6-7-8-9-10-11-12-13 mm
○ 900L 3-4-5-6-7 mm
○ 900ME 3-4-5-6-7 mm
● 900LP 0,8x4-1x5,5-1,2x6,5-1,2x8 mm
● 900PH PH1-PH2-PH3-PH4
○ 900TX T10-T15-T20-T25-T27-T30-T40
900/20 50 mm - 900/20L 100 mm
900/21 150 mm
900/25
900BG/31
900/42
○ 900/55
○ 920A 8-10-11-12-13-14-15-16-17-18-19-20-21-22-23-24-26-27-28-30-32 mm
920/15 - 920/25
920AN/125 125 mm
920AN/250 250 mm
920/42
○ 920/55
○ 920FTX 10-12-14-16-18-20-22-24 mm
○ 920AL 10-12-13-14-15-16-17-18-19-21-22 mm

NEW

M105MH

7,7 kg **024500114**

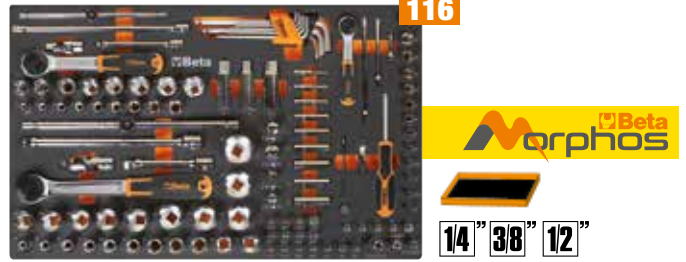

116

Beta Morphos

1/4" 3/8" 12"

○ 900 4-4,5-5-5,5-6-7-8-9-10-11-12-13-14 mm
○ 900L 5-6-7-8-9-10-11-12-13 mm
○ 96BPC/SC9 1,5-2-2,5-3-4-5-6-8-10 mm
895/1 - 895/3 - 895/6
○ 900ME 3-4-5-6-7 mm
● 900LP 0,8x4-1x5,5-1,2x6,5-1,2x8 mm
● 900PH PH1-PH2-PH3-PH4
○ 900TX T10-T15-T20-T25-T27-T30-T40
900/16 □ 1/4 - ■ 3/8
900/... 50-100-150 mm
900/25 - 900BG/31 - 900/42
○ 900/55
○ 910A 6-7-8-9-10-11-12-13-14-15-16-17-18-19-20-21-22 mm
910/15 □ 3/8 - ■ 1/4
910/16 □ 3/8 - ■ 1/2
910/21 125 mm
910/22 250 mm
910/25 - 910/42
○ 910/55
○ 920A 8-10-11-12-13-14-15-16-17-18-19-20-21-22-23-24-26-27-28-30-32 mm
920/15 □ 1/2 - ■ 3/8
920/25
920AN 125 - 250 mm
920/42
○ 920/55
○ 956E 16-17,8-20,8 mm

NEW

M120

6,9 kg **024500120**



75

12"

○ 920A 10-11-12-13-14-15-16-17-18-19-20-21-22-24-26-27-30-32 mm
920AN/125 125 mm
920AN/250 250 mm
920/25 - 920/42
○ 920AL 10-12-13-14-15-16-17-18-19-22-24-27-30-32 mm
○ 920FTX 10-12-14-16-18-20-22-24 mm
○ 920/55
○ 920PE 5-5L-6-6L-7-7L-8-8L-10-10L-12-12L-14-14L
T20-T25-T27-T30-T40-T45-T50-T55-T60-T20L-T25L-T27L-T30L-T40L-T45L-T50L

M125

7,9 kg 024500872



68

38" 12"

- 910AL 8-9-10-11-12-13-14-15-16-17-19-21-22 mm
- 920FTX E12-E14-E16-E18-E20-E22-E24
- 920PE 5-6-6L-7-8-8L-10-10L-12-12L mm
- 920TX T20-T25-T27-T30-T30L-T40-T40L-T45-T50-T50L-T55-T60-T60L
- 920XZN 5-6-6L-8-8L-10-10L-12L mm
- 920AL 10-12-13-14-15-16-17-18-19-21-22-23-24-27-30-32 mm
- 1692/5 5 m

M195MH

3,4 kg 024500196

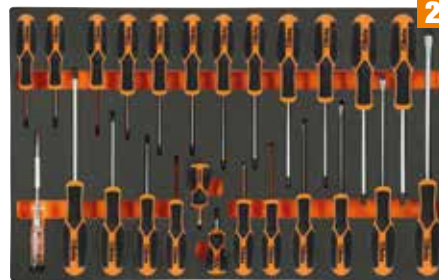

25



- 1253 3,5x100 mm
- 1221 2,5x50 - 3x75 - 4x100 - 5,5x125 - 6,5x150 - 8x200 mm
- 1222 PH0x60 - PH1x80 - PH2x100 - PH3x150 mm
- 1222N PH1X30 mm
- 1227TX T6-T7-T8-T9-T10-T15-T20-T25-T27-T30-T40-T45
- 1221N 4x30 mm

NEW

M129

3,4 kg 024500147



13

- | | | |
|---------------|----------------|-----------------|
| ○ 1032 180 mm | 1052 240 mm | ■ 1150BM 180 mm |
| ○ 1034 170 mm | 1082BM 160 mm | ● 1166BM 160 mm |
| ● 1036 175 mm | 1098 220 mm | ● 1168BM 160 mm |
| ● 1038 175 mm | 1122 250 mm | |
| 1048N 250 mm | 1128BMX 147 mm | |

NEW

M213

1,8 kg 024500213



25



- 1201E 2,5x50-3x75-4x100-5,5x125-6,5x150-8x200 mm
- 1201EN 4x30 mm
- 1202E PH0x60-PH1x80-PH2x100-PH3x150 mm
- 1202EN PH1X30 mm
- 1207E/TX T6-T7-T8-T9-T10-T15-T20-T25-T27-T30-T40-T45
- 1253 3,5x100 mm

M166MH

2,9 kg 024500881



49



- ○ ● ● ● 861MIX/A31
- 1048N 250 mm
- 1221 3x75 - 4x100 - 5,5x100 - 6,5x150 - 8x150 mm
- 1221N 6,5x30 mm
- 1222 4,5x80 - 6x100 - 8x150 mm
- 1222N 6x30 mm
- 1227TX T20-T25-T27-T30
- 1082BM 160 mm
- 1150BM 180 mm
- 1162BM 160 mm

NEW

M230

3,2 kg 024500230



25

- | | | |
|--------------------|---------------------|---------------|
| ■ 1719BMA/Q 200 mm | 1737NX | 35 200-250 mm |
| ▲ 1719BMA/T 200 mm | 1771 170 mm | 36 125 mm |
| ▲ 1719BMA/P 200 mm | 30 Ø 2-3-4 mm | 1370 500 g |
| ▶ 1719BMA/M 200 mm | 31 Ø 2-3-4-5-6-8 mm | 1390 Ø 35 mm |
| ● 1719BMA/R 200 mm | 32 Ø 4 mm 34 150 mm | 1692 3 m |
| | | 1712TF |

M320

5 kg 024500320



146

IMPACT DRILL 20V 1972/K20V-13BMC



- 410MIX/SEL19
- 861/C100
- 862F/A7
- 862XP/A16
- 1972/K20V-13BMC



SOFT MODULE SYSTEM

FOR 140 mm DRAWERS

T01 024240001
 2,7 kg



17
 42 6-7-8-10-11-12-13-14-16-17-18-19-21-22-24-27-30 mm

T05 024240005
 1,5 kg



16
 42 6-7-8-10-11-12-13-14-16-17-18-19-21-22-24-27-30 mm

T06 024240006
 2,1 kg



5
 42 22-24-27-30-32 mm

T31 024240031
 3 kg



27
 31 Ø 2-3-4-5-6 mm 32 Ø 4 mm
 55 6x7-8x9-10x11-12x13-14x15-16x17-18x19
 20x22-21x23-24x26-27x29-30x32 mm
 ○ 96N/SC9 1,5±10 mm

T45 024240045
 1,3 kg

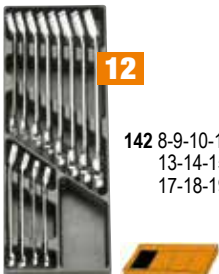

12
 142 8-9-10-11-12-13-14-15-16-17-18-19 mm

T50 024240050
 1,3 kg



11
 ○ 96T 2-2,5-3-3,5-4-4,5-5-6-7-8-10 mm

T63 024240063
 3,8 kg



8
 ○ 952 7-8-10-12-13-14-17-19 mm

T68 024240068
 590 g



6
 ○ 951 2,5-3-4-5-6-8 mm

T80 024240080
 4,1 kg

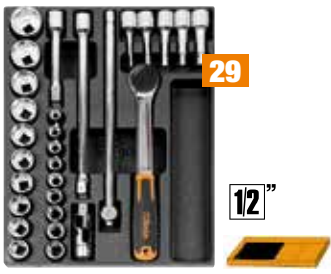

29
 12"
 ○ 920A 10-11-12-13-14-15-16-17-18-19
 20-21-22-23-24-26-27-30-32 mm
 ○ 920ME 5-6-8-10-12 mm
 920/21 125 mm 920/22 255 mm
 920/25 - 920/42 305 mm ⊕ 920/55

T91MH 024240098
 560 g



25
 14"
 ○ 900 4-4,5-5-5,5-6-7-8-9-10-11-12-13-14 mm
 ○ 900ME 2,5-3-4-5-6-8 mm
 900/20 50 mm 900/21 150 mm
 900/25 - 900BG/31 - 900/42 115 mm ⊕ 900/55

T92 024240092
 1,5 kg



22
 38"
 ○ 910A 6-7-8-9-10-11-12-13-14-15-16-17-18-19-20-21-22 mm
 910/21 125 mm 910/42 210 mm
 910/22 250 mm ⊕ 910/55
 910/25

T137 024240137
 750 g



3
 ⊚ 1084BM 160 mm
 ⊚ 1150BM 180 mm
 ⊚ 1166BM 160 mm

T145 024240145
 640 g

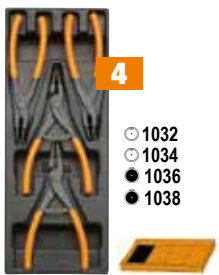

4
 ○ 1032 180 mm
 ○ 1034 170 mm
 ● 1036 175 mm
 ● 1038 175 mm

T167MH 024240182
 1,3 kg



11
 ● 1221 3x75-3x100-4x100-4x150-5,5x100
 5,5x150-6,5x150-8x150-10x200 mm
 ● 1221N 4x30 - 6,5x30 mm

T234 024240234
 1,3 kg

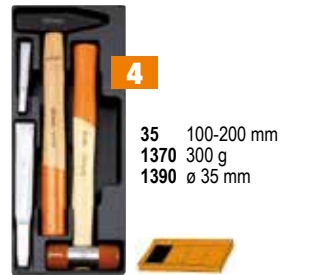

4
 35 100-200 mm
 1370 300 g
 1390 ø 35 mm

T236 024240236
 870 g



5
 ■ 1719BMA/Q 200 mm
 ▲ 1719BMA/T 200 mm
 ▨ 1719BMA/P 200 mm
 ▸ 1719BMA/M 200 mm
 ● 1719BMA/R 200 mm

MODULAR line

MODULAR WORKBENCHES



C58BC-W2,1 4CA+SVR LED

169,5 kg

Workbench, 2.1 m long, with wood top, 4 drawers and door module

- Multi-ply wood worktop (2,100x750 mm), 38 mm thick
- 4 drawers (367x588 mm) with ball bearing slides:
 - 2 drawers 70 mm high
 - 2 drawers 140 mm high.
- Drawer bases protected by foamed rubber mats
- **Each drawer can accommodate up to 4 EVA foam or ABS thermoformed trays**
- Front centralized lock
- 1 door module with lock
- Steel frame with 4 supporting legs
- Holes for a vice (1599F/150 - 1599GI/150, to be ordered separately)
- 2 lower half-shelves for objects, 1,788x335 mm, 40 mm thick
- Static load capacity: 800 kg, uniformly distributed
- Can be fixed to floor
- **Kit with 4 perforated tool panels**
- **2 LED lamp tracks IP20**



Ral 2011	Ral 7016
Ral 7016	
058000743	058000748

NEW

C58BC-2,1

Simple workbench, 2.1 m long

- Lower half-shelf for objects, 1,788x335 mm; thickness: 40 mm
- Steel frame with 4 supporting legs
- Holes for a vice (1599F/150 - 1599GI/150, to be ordered separately)
- Can be fixed to floor



C58BC-W2,1

70 kg 058000621



- Worktop (2,100x750 mm) made from **multi-ply wood**, 38 mm thick

C58BC-X2,1

93 kg 058000626



- Worktop (2,100x750 mm) made from **stainless steel coated MDF**, 38 mm thick

8888/KPS

088880813

Kit of nonslip PVC tiles

Contents:

- 10 modular nonslip PVC tiles, 500x500x80 mm (art. PCP)
- 10 yellow male jointed chutes (art. SCG/M)
- 10 yellow female jointed chutes (art. SCG/F)

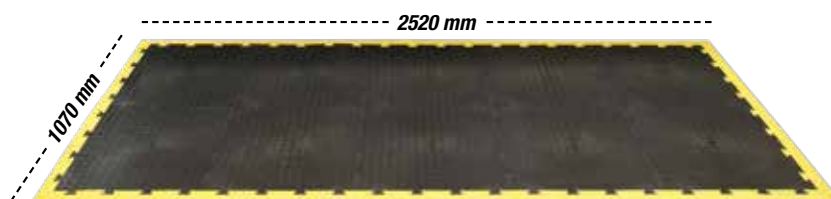

NEW

C56BLP

11,4 kg 05600005

Multi-purpose folding workbench

- Worktop (820x630 mm) made from polypropylene, with graduation in millimetres and inches
- Handle for easy transportation
- Lower shelf for objects
- Telescopic aluminium legs (550-820 mm)
- Can be used as a stand
- Non-slip feet

FIXED ACCESSORIES INCLUDED



ONLY 11,4 kg!

READY FOR USE IN JUST A FEW SECONDS, EASY TO CARRY AND STORE IN SMALL SPACES



C56PL O

18,5 kg 056000021

Folding workbench lightweight reliable

- Lightweight, easy to carry.
- Worktop (800x500mm) made of galvanized sheet iron, for use on one side, protected by an anti-oil and anti-petrol rubber cover.
- Handle with rubber cover, for easy transportation
- An additional sturdy, reliable worktop, always within reach



ONLY 18,5 kg

C51

21 kg

Trolley

- 3 tops covered in antislip ribbed rubber
- Two fixing options for central worktop
- Four castors Ø 100 mm: 2 fixed and 2 steering (1 with brake)



Ral 2011	Ral 7016	Ral 3000
051000001	051000002	051000003

C48M

140 kg

048000230



Electric platform cart, with panels

- Motorized platform, with 24V - 400W motor with 2x12V 33Ah battery supply and Curtis control card
- Loading floor made from sturdy steel, coated with non-slip rubber, with round tubular panels preventing objects from falling during transport
- The panels can be removed, to cater to individual transportation requirements
- Fitted with 2 pneumatic traction wheels (Ø 260 mm) and 2 swivelling rubber wheels (Ø 150mm), electromagnetic brake and differential gear
- Supplied with an external battery charger, 220V/50Hz - V/A 24/12

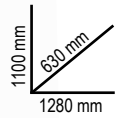

FUNCTIONAL SPECIFICATIONS

- Carrying capacity: 400 kg
- Driving speed: 4-6 km/h (adjustable)
- Battery life: 4 hours
- Maximum permitted slope with a full load: 6%
- Maximum permitted slope with 100 kg load: 18%

TECHNICAL SPECIFICATIONS

- Overall dimensions: 1280x630x1100h mm
- Useful dimensions of loading platform with panels: 1180x580 mm
- Useful dimensions of loading platform without panels: 1260x620 mm
- Height of loading platform from floor: 320 mm
- Height of battery compartment from floor: 65 mm
- Weight with batteries: 140 kg

SAFETY DEVICES:

- Electronic brake
- Buzzer
- Anti-crushing guard
- Battery charge indicator
- Curtis control cart

C48P

11 kg

048000030

Folding tool trolley

- Loading platform made of reinforced polypropylene (PP), with non-slip coating and TPV inserts for corner protection
- Retractable handle for quick, compact storage
- Four non-marking castors, Ø 125 mm: 2 fixed and 2 steering with brakes
- Maximum capacity: 300 kg.
- Loading platform working width: 705 mm
- Loading platform depth: 480 mm
- Loading platform height: 200 mm



300 kg



3069

69,5 kg

030690000

Manual pallet truck



Features:

- 2 steering wheels, 200x50 mm, made of PU
- Double front rollers, 80x70 mm, made of PU
- Pallet access entry and exit rollers
- Depth stop notch
- Lowering speed control valve
- Safety overload valve
- **3-position operating lever**

Technical data:

- Maximum capacity: 2500 kg
- Overall length: 1550 mm
- Fork length: 1150 mm
- Fork width: 540 mm
- Individual fork width: 160 mm
- Lever height: 1230 mm
- Max. lifting height: 115 mm
- Pallet storage corridor: 800x1200 lengthwise: 1805 mm
- Turning radius: 1347 mm



1150 mm

2500 kg

C41H

21 kg

Two-module tool trolley

- Sheet metal frame and plastic tops, synonymous with remarkable sturdiness and reduced weight
- 2 detachable modules:
 - 1 upper tool box,
 - 1 module with 2 drawers 95 mm in height, 1 pull-out case made of plastic, 66 mm high, and 1 drawer 295 mm in height
- Oversized castors (160 mm), built into frame for easy transport - for example, on steps
- Side centralized lock for closing drawers of lower module
- Drawers with ball bearing slides and double closing hook
- Telescopic aluminium handle
- Small tool holder built into upper tool box
- Lower drawer with double ball bearing slide



- 04100002
- 04100021
- 04100012
- 04100008
- 04100006
- 04100010
- 04100005



Five-section cantilever tool box, made from sheet metal, empty

C20

4,3 kg **02120001**

450x200x210 mm

C20L

5,7 kg **02120002**

550x200x210 mm



CP15L

2,9 kg **021150202**

Tool box, long series, made from plastic, removable tote-tray and tool trays

- 3 tool trays built into cover with adjustable partitions
- 1 interior tote-tray with adjustable partitions

558x277x270 mm



CP17

2,1 kg **021170500**

Tool box, made of stainless steel and plastic, removable tote-tray

500x200x220 mm



Tool trunk, made of sheet metal, empty



C22B-O

13 kg **022000150**

720x320x310 mm

C22BM-O

20 kg **022000160**

850x360x350 mm

C22BL-O

26 kg **022000170**

1010x410x400 mm

Organizer tool case, with 15 compartments

The perfect solution for carrying smallwares, including screws, nuts, washers, rivets and dowels.

Can be put on top, and hooked to, each other



2080/DS

📦 760 g 📦 020800210

SMALL 10 removable partitions

📏 375x315x65 mm

2080/DL

📦 970 g 📦 020800211

LARGE 8 removable partitions

📏 440x330x75 mm

2028/VV

📦 4,7 kg 📦 020280010

Tool case, made of polypropylene, empty

- 2 tool panels
- Interior bottom with removable partitions
- Double combination lock



📏 480x190x400 mm



C5

📦 2,8 kg 📦 021050000

Rucksack, empty

- Removable interior tool panel
- Six exterior pockets and two interior pockets
- Waterproof plastic base
- Double safety lace for fixing rucksack to shoulders
- Ergonomic padded back



📏 400x200x500 mm

2080/V12

📦 1,8 kg 📦 020800000

Organizer tool case with 12 removable tote-trays

Removable, folding clear tote-trays, for immediate recognition of contents



📏 300x330x145 mm



2031/TV

📦 5,2 kg 📦 020310200

Tool trolley made from thick polypropylene, aluminium profile, empty

- 3 tool panels
- Telescopic handle
- Ball bearing castors
- Interior bottom with removable partitions



📏 475x235x385 mm



NEW

C6T

📦 4,9 kg 📦 021060010

Rucksack with castors, empty

- Telescopic handle for easy transport
- Built-in castors with practical dustproof cover for use as a rucksack
- Two removable tool panels
- Interior PC pocket and five exterior pockets
- Waterproof plastic base



📏 360x200x480 mm

CSM

1,9 kg **021050050**

Technical fabric tool rucksack, empty

- Large front compartment with zip closure, complete with:
 - 4 exterior rows of elastic bands for quick access to tools
 - 6 interior tool pockets, for efficient technical organisation
- Two convenient side pockets with zip closure, badge holder and elastic tool band



370x210x510 mm

Rucksack interior:

- 3 rows of elastic tool bands
- 10 differently sized tool pockets
- Central padded handle on rucksack top for firm, balanced hold
 - Adjustable reinforced shoulder straps
- Ergonomic padded back
 - Plastic-reinforced, water-resistant base



NEW

CBA

5,9 kg **021080400**

Technical fabric tool trolley, empty

- Semi-rigid frame
- Telescopic carrying handle for easy transportation
- 4 pivoting castors
- Double padded handle for safe, balanced hold
- Convenient semi-rigid front compartment accommodating personal belongings
- Large lower compartment with 5 tool pockets and elastic tool bands
- 33 interior tool pockets
- 6 interior rows of elastic tool bands
- 6 side rows of elastic tool bands, with sturdy metal measuring tape hook
- Plastic interior pocket with zip closure



455x270x480 mm

NEW

C8

5,5 kg **021080000**

Technical fabric tool trolley, empty

- Telescopic carrying handle
- 2 removable interior tool panels
- 2 exterior front pockets
- Can accommodate tool box item C10S

Technical fabric tool box, empty

- Hard frame
- Double bottom
- Tilting handle for easier access to tools
- Elastic tool bands and interior and exterior pockets
- Cover
- Tool tray included in double bottom
- Can be used with trolley C8



470x280x380 mm



C10S **2,9 kg** **021100001**

420x220x250 mm

C10 **3,3 kg** **021100000**

520x220x250 mm

C11

1,8 kg **021110000**

Technical fabric tool box, empty

- Hard water resistant plastic base
- Elastic tool bands and interior and exterior tool pockets
- Document holders built into double bottom of cover

410x230x250 mm



C3

917 g **021030000**

Mini tool bag, made from technical fabric, empty

- 1 exterior front pocket with zip closure
- 2 side pockets with tote trays
- 1 convenient rear pocket with Velcro closure
- 1 removable interior tool panel, with elastic bands on both sides
- Complete with shoulder strap
- USB interface for charging mobile devices



230x110x320 mm

A MINI TOOL BAG TO ALWAYS BRING WITH YOU!

C7

4 kg **021070000**

Technical fabric tool bag, empty

- 2 removable interior tool panels
- 2 exterior front pockets
- Interior bottom made of plastic, with removable partitions



480x165x380 mm



2005MMT

500 g **020050070**

Tool pouch with belt, empty

- Large front compartment accommodating a convenient roll-up wallet with tool pockets and elastic tool bands
- Two large storage pockets, including one with strap closure
- Interior front pocket with zip closure
- Double pouch closure, with strap and buckle
- Breathable belt with stretch band and two storage pockets



250x160x100 mm

NEW

2001/BZ27 VU

3,9 kg **020010157**

Folding tool case with assortment of 27 tools, for universal use



380x290x60 mm



27

Quantity/Description	Beta N.
1 electrician's scissors, straight blades	1128BMX
1 combination pliers 180 mm	1150
6 combination wrenches 7-8-10-13-17-19 mm	42
3 screwdriver for slotted head screws	1201E
• 3x75 - 4x100 - 5,5x150 mm	
3 screwdriver for cross head Phillips® screws	1202E
• PH0x60 - PH1x80 - PH2x100 mm	
9 offset hexagon key wrenches	96/SC9
• 1,5-2-2,5-3-4-5-6-8-10 mm	
1 engineer's hammer 300 g	1370
1 slip joint pliers boxed joints 250 mm	1048N
1 measuring tape 5 m	1692/5
1 snap - off blade utility knife 18 mm	1771

BETA'S ICONIC WRENCH

42

A stylish, slim shape enhanced by a slender profile, lighter to the touch.



The strength, resilience and ergonomic design of the Beta wrench reach even higher values, to provide users with the best possible tool. The manufacturing process is carried out in our factories in Sovico and Sulmona, on the basis of state-of-the-art automation technology and the best trained workers



POWERFUL

Torque values more than doubled compared to the requirements to be satisfied under ISO 1711.

STRENGTH

Remarkable strength: in case of improper use, the wrench buckles, without breaking suddenly and dangerously.

ERGONOMIC

The offset ring has a 15 degree angle to protect the hand. The shape is obtained from a die; it is not bent later.



42/SP15



000421078

Set of 15 combination wrenches

- Supplied with a comfortable, practical holder



6-7-8-9-10-11-12-13-14-15-16-17-19-22-24 mm

42/S26

000421070

Set of 26 combination wrenches



6-7-8-9-10-11-12-13-14-15-16-17-18-19-20-21-22-23-24-25-26-27-28-29-30-32 mm

55/B12N

000550164

Set of 12 double open end wrenches in roll-up wallet made of durable polyester



6x7-8x9-10x11-12x13-14x15-16x17-18x19-20x22-21x23-24x26-25x28-30x32 mm



141/B9

001410069

Set of 9 ratcheting combination wrenches, straight series, in cloth wallet



8-10-11-12-13-14-15-17-19 mm





42/SC8

000421086

Set of 8 combination wrenches with compact support

8-10-12-13-14-15-17-19 mm



NEW

142SN/SC8

001420258

Set of 8 swivel end ratcheting combination wrenches, with compact support

8-10-12-13-14-15-17-19 mm



NEW

142/SC8

001420086

Set of 8 reversible ratcheting combination wrenches, with compact support

8-10-12-13-14-15-17-19 mm



NEW

192/52

001920070

Set of 2 reversible ratcheting offset bi-hex ring wrenches



8 SIZES IN 2 WRENCHES



186 8-32

001860008

Self-locking wrench with automatic take-up device for hexagons, 8 to 32 mm

Ideal for hexagon, Spline, square and Torx® head screws, including damaged screws

L 260 mm

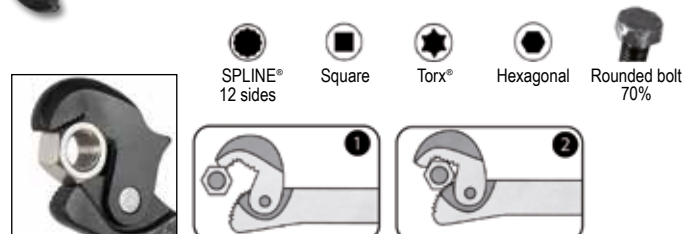

THE ADJUSTABLE WRENCHES WITH SCALES

111

Beta 111 allow differently sized nuts and bolts to be tightened and loosened through the sliding jaws, which can be adjusted through the central rolls.



- Special heat treatment for excellent **wear resistance**.
- Based on the new ergonomic properties, weight has been **reduced by 20%**

1 Head angled at 15°, allowing hardly accessible spaces to be reached, as is the case with our iconic combination wrenches, "42"

2 Double laser marking in mm/inches

3 Made from high-performance alloy steel for increased mechanical torsional strength

4 Hole on handle for hanging wrench



111CM 220

Wide opening adjustable wrenches, **CHROME-PLATED**, short series

- Right-hand rotation of pin



L mm	L "	A max mm
220	8	38

111E

Adjustable wrenches with scales, **CHROME-PLATED**

- Right-hand rotation of pin



	L mm	L "	A max mm	
111E 150	150	6	24	001110115
111E 200	200	8	29	001110120
111E 250	250	10	34	001110125
111E 300	300	12	40	001110130

111E/D3

Set of 3 adjustable wrenches with scales, **CHROME-PLATED**



001110163



111ER

Adjustable wrenches with scales, **phosphated**

- Reversible jaw for optimal hold
- Double laser marking in mm/inches



RIGHT-HAND ROTATION

	L mm	L "	A max mm	
111ER 200	200	8	29	001110520
111ER 250	250	10	34	001110525
111ER 300	300	12	40	001110530

96/SC9

Set of 9 offset hexagon key wrenches



Ø mm	L mm
1,5	45
2	50
2,5	57
3	64
4	72
5	83
6	94
8	105
10	119

96BPC/SC9

Set of 9 ball head offset hexagon key wrenches

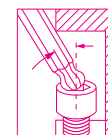

Ø mm	L mm
1,5	79
2	84
2,5	89
3	99
4	108
5	126
6	148
8	168
10	187

97BTX/SC8

Set of 8 ball head offset key wrenches, long model, for Torx® head screws



Ø mm	L mm
T9	62
T10	71
T15	81
T20	92
T25	94
T27	105
T30	114
T40	129

97BTXL/SC8

Set of 8 ball head offset key wrenches, long model, for Torx® head screws



Ø mm	L mm
T9	80
T10	86
T15	100
T20	110
T25	126
T27	140
T30	160
T40	176

97BRTXL/SC8

Set of 8 ball head offset key wrenches, long model, for Tamper Resistant Torx® head screws



Ø mm	L mm
T9	80
T10	86
T15	100
T20	110
T25	126
T27	140
T30	160
T40	176

96LBP/SC9

Set of 9 ball head offset hexagon key wrenches



Ø mm	L mm
1,5	90
2	100
2,5	112
3	127
4	144
5	163
6	184
8	204
10	230

96BP-HO/SC9

Set of 9 ball head offset hexagon key wrenches, with screw holding system

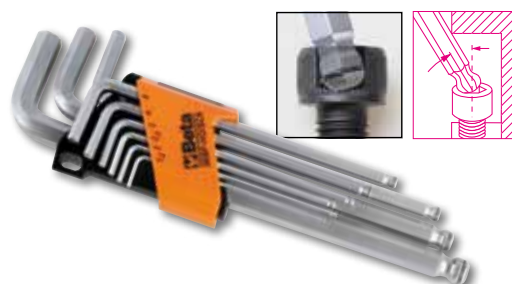

Ø mm	L mm
1,5	79
2	84
2,5	89
3	99
4	100
5	126
6	148
8	168
10	187

96BPA/SC9

Set of 9 ball head offset hexagon key wrenches, 110°, extra-short side model

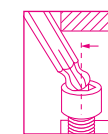

Ø mm	L mm
1,5	71
2	86
2,5	96
3	104
4	116
5	132
6	155
8	176
10	200

96T/55P

Set of 5 offset hexagon key wrenches with handles



○ 2,5-3-4-5-6 mm



97TTX/56

Set of 6 ball head offset key wrenches for Torx® head screws with handles



○ T10-T15-T20
T25-T30-T40



951 THE ORIGINAL ONE

When this wrench was launched, back in 1980, it was a revolution. Designed to work on high-resistance screws, it is the name for quick handling, accurate fit and flexible use. The hexagon T handle can be adjusted as required. The hexagon ends are designed to transmit the maximum possible torque to the screw. The rod length allows remarkable torques to be effortlessly applied to the screws. Ongoing production improvements have translated, for example, into sandblasted finishes and sharp-edged hexagon ends which allow a better fit onto any screws, including damaged ones. Laser marking results in a sturdier rod.

952 THE RELIABLE ONE

Reliable, precise pre-positioning is the secret for the success of this wrench. The articulated joint maintains its function over the years, no adjustment being required. Socket rotation angle: 50°. Can be used at 90° in fixed position. Sliding T-handle, can be stopped in the required position throughout its length. Triple size marking on head.

951/56

Set of 6 T-handle wrenches with three hexagon male ends



○ 2,5-3-4-5-6-8 mm



952/D7

Set of 7 T-handle wrenches with swivelling hexagon sockets



○ 7-8-10-12
13-14-17 mm

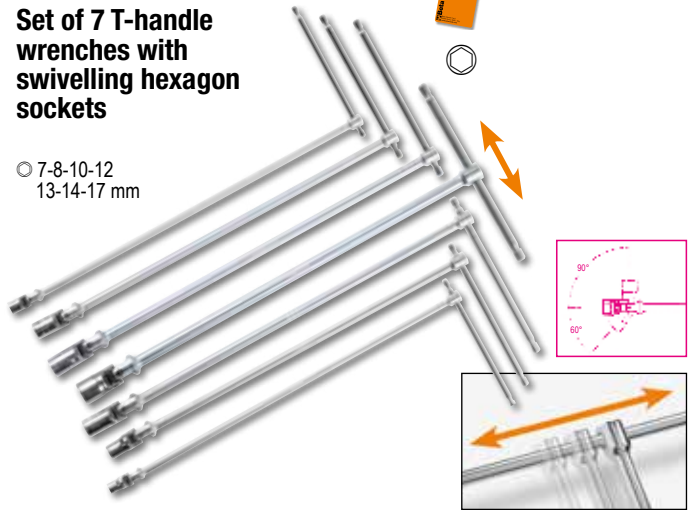

950/D6

Set of 6 T-handle hexagon socket wrenches

○ 7-8-10-13-17-19 mm



COLOR CODE

96BP-CL/SC9

Set of 9 ball head offset key wrenches, coloured

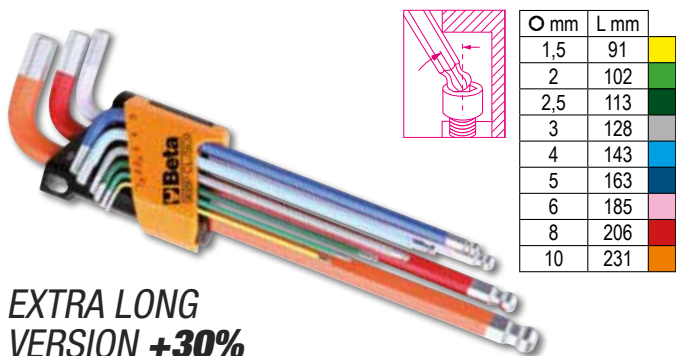

EXTRA LONG
VERSION +30%

97BTX-C/SC8

Set of 8 coloured ball head offset key wrenches, for Torx® head screws

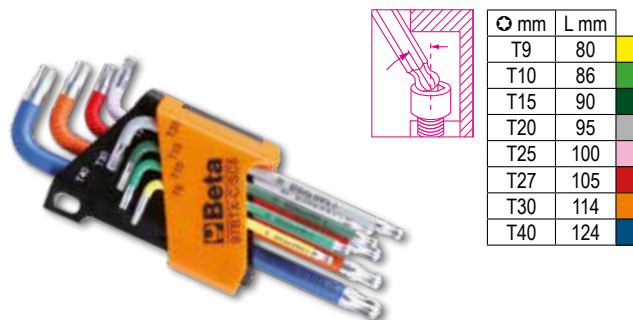

860/C38P

1 reversible ratchet bit holder with articulated handle, 27 bits, 8 hexagon sockets and 2 accessories

- 860LP 0,6x4,5-0,8x5,5-1,0x5,5-1,2x6,5 mm
- 860PE 2-2,5-3-4(x2)-5(x2)mm
- 860PH PH1(x2)-PH2(x2)-PH3
- 860TX T10-T15-T20-T25-T30-T40
- 860PZ PZ1(x2)-PZ2(x2)-PZ3
- 900 5-5,5-6-7-8-9-10-13 mm
- 892/0 1/4 1/4
- 892/3 1/4 1/4
- 855P 240 mm



270x120x45 mm

860/C27

25 bits, 1 connector and 1 reversible ratchet in plastic case



- 860LP 0,5x3-1,0x5,5-1,2x6,5 mm
- 860PE 2-2,5-3-4-5-6 mm
- 860PH PH1-PH2(x2)-PH3
- 860TX T6-T8-T10-T15-T20-T25-T30-T40
- 860PZ PZ1-PZ2(2x)-PZ3
- 860/55 100 mm
- 892/0 1/4 1/4



1257LPH/S8

Set of 8 micro-screwdrivers for slotted head screws and Phillips® screws in hard case



- 1257PH PH00-PH0-PH1
- 1257LP 0,4x2-0,4x2,5-0,5x3
- 0,6x3,5-0,8x4 mm



180x120x50 mm

1243/D7

012430017

Set of 7 screwdrivers with steel heads

1241 ● 5,5x100-6,5x125-8x150-10x200 mm
1242 ⊕ PH1x100-PH2x100-PH3x150 mm



1203E/D5

012031001

Set of 5 screwdrivers

1201E ● 3,5x100-5,5x150-6,5x150 mm
1202E ⊕ PH1x80-PH2x100 mm



1203E/D8P

012031018

Set of 8 screwdrivers

1201E ● 2,5x50-3x75-4x100-5,5x100-6,5x150 mm
1202E ⊕ PH0x60-PH1x80-PH2x100 mm



1203E/D10N

012031019

Set of 10 screwdrivers

1201E ● 2,5x50-3x75-4x100-5,5x150-6,5x150 mm
1202E ⊕ PH0x60-PH1x80-PH2x100 mm
1201EN ● 4x30 mm
1202EN ⊕ PH1x30 mm



1207E/TX-D7

012071207

Set of 7 screwdrivers

1207E/TX ⊕ T6-T8-T10-T15-T20-T25-T30



Beta **EVOX**
THE EVOLUTION OF
THE SCREWDRIVER!

Beta **EVOX-E**

THE FUNCTIONAL, ERGONOMIC BETA EVOX SCREWDRIVER IS ALSO ELECTRICAL NOW!



Technical data:

- 3.7V 2300mAh lithium battery
- Maximum torque in electric mode: 1.2 Nm
- **Over 1,000 screw fastenings at 1.2 Nm per charging cycle**
- **Speed: 250 rpm**
- **Outstanding static resistance (up to 12 Nm, manual tightening)**
- Outstanding mechanical resistance
- 1/4" magnetic bit holder
- Compatible with all standardized bits

- Rechargeable via USB-C cable (included)
- USB-C port protected with screw cap
- Front ring LEDs for improved visibility of working area
- When charging, steady LEDs indicate that charging is complete
- Ergonomic nylon handle inspired by Evox screwdriver
- Built-in and sealed operation buttons
- Convenient belt pouch with bit pockets (6 mixed bits included)

1210E/GE

012100701

Evox-E electric screwdriver



6x



1211E/GE

012110701

Evox-E electric screwdriver

⚠ **1000 V**
● ● ● ● ● ●

6x



NEW

Morphos

THE SCREWDRIVER THAT ADAPTS TO THE SHAPE OF YOUR HAND

1 HANDLE

The handle relies on an innovative **three-material** frame: the polypropylene body ensures firmness, whereas an inner ultrasoft TPR layer, placed at the points of contact with the palm, is subject to controlled deformation, in order to adapt to the hand and provide improved transmission and comfort.

- 2 Triangular section for **reduced rolling on worktop**
- 3 Relief texture for **improved grip – for example, under the toughest work conditions**

- 4  Immediate blade identification on head

- 5 Black phosphated tip for more accurate coupling with the screw and improved wear resistance



TORQUE

In-house laboratory tests have shown the ability to transmit **MORE THAN 30% ADDITIONAL TORQUE COMPARED TO THE PREVIOUS MODELS.**

REDUCED EFFORT AND HIGHER PERFORMANCE IN EACH APPLICATION

1223/D5



012230001

Set of 5 screwdrivers



- 1221 ● 3,5x100-5,5x150-6,5x150 mm
- 1222 ⊕ PH1x80 - PH2x100 mm

1223/D6



012230006

Set of 6 screwdrivers



- 1222 ⊕ PH1x80 - PH2x100
- 1224 ● 2,5x60-x3x100-x4x100-5x125 mm

1223/D8P



012230018

Set of 8 screwdrivers



- 1221 ● 2,5x50-3x75-4x100-5,5x100-6,5x150 mm
- 1222 ⊕ PH0x60 - PH1x80 - PH2x100

1223/D10N



012230019

Set of 10 screwdrivers



- 1221 ● 2,5x50-3x75-4x100-5,5x150 6,5x150 mm
- 1221N ● 4x30 mm
- 1222 ⊕ PH0x60 - PH1x80 - PH2x100
- 1222N ⊕ PH1x80

1227TX/D7



012270207

Set of 7 screwdrivers



- 1207E/TX ⊙ T5-T6-T8-T10-T15-T20-T25



1/4 Set of 10 bits with magnetic bit holder, in pocket case

861MIX/A10



008610800

- 861LP 0,5x3-1x5,5-1,2x6,5 mm
- ⊕ 861PH PH1-PH2(x2)-PH3
- ⊕ 861PZ PZ1-PZ2-PZ3
- 882M1 ○ 1/4 ● 1/4

861PE/A10



008610820

- 861PE 2-2,5-3(x2)-4(x2)
5(x2)-6-8 mm
- 882M1 ○ 1/4 ● 1/4

861PHZ/A10



008610810

- ⊕ 861PH PH1-PH2(x3)-PH3
- ⊕ 861PZ PZ1-PZ2(x3)-PZ3
- 882M1 ○ 1/4 ● 1/4

861TX/A10



008610870

- ⊕ 861TX T7-T8-T9-T10-T15
T20-T25-T27-T30-T40
- 882M1 ○ 1/4 ● 1/4



862F/A7



008620950

Set of 7 magnetic bits,
hexagon sockets,
in plastic case

- 5,5-6-7-8-10-12-13 mm

7x



862XP/A16



008620960

Set of 16 impact bits
in pocket-size case

- IMPACT
- ⊕ PH2(x2)-PH3
 - ⊕ PZ2(x2)-PZ3
 - T20-T25(x2)-T30(x2)-T40(x2)
 - 4-5-6 mm

1/4



16x



861/C100

008616998

Case with 98 bits and 2 bit holders

- For manual, electric and pneumatic screwdrivers

100x



155x117x37 mm

1/4

●	861LP	3-4-4,5-5,5(x3)-6,5(x2)-8(x2) mm
⊕	861PH	PH0(x2)-PH1(x3)-PH2(x3)-PH3(x2)-PH4
⊕	861PZ	PZ1(x3)-PZ2(x3)-PZ3(x2)-PZ4
○	861PE	2-2,5(x2)-3(x2)-4(x2)-5(x2)-6(x2)-8-10 mm
⊕	861TX	T6-T7-T8-T9-T10(x2)-T15-T20(x2)-T25(x2)-T27-T30(x2)-T40(x2)
⊕	861RTX	T6-T7-T8-T10-T15-T20-T25-T27-T30-T40
⊕	861XZN	M5-M6-M8
⊕	861TQS	0-1-2-3-4-5-6-8-10
⊕	861TRW	1-2-3-4-5-6
⊕	861SP	4-6-8-10-12
○	861SQ	0-1(x2)-2(x2)-3

1256/C36-2

012560100

Bi-material microscrewdriver
with 36 interchangeable
4-mm bits and magnetic extension

38x



130x60x35 mm

4mm

—	1256TX	⊕	T3-T4-T5-T6-T7-T8-T9-T10-T15
—	1256RTX	⊕	T6-T7-T8-T9-T10
—	1256LP	●	0,8-1,2-1,5-1,8-2,2-2,5-3-3,5-4 mm
—	1256PE	○	0,7-0,9-1,3-1,5-2 mm
—	1256PH	⊕	PH000-PH00-PH0-PH1
—	1256PZ	⊕	PZ000-PZ00-PZ0-PZ1
—	1256/20		
—	1256/30		

900/C39N

Assortment of 11 hexagon sockets, 21 bits and 7 accessories, in plastic case

009000947

14" 1/4"



39x

150x97x53 mm

	900	5-5,5-6-7-8-9-10-11-12-13-14 mm	11
	900/20	50 mm	1
	900/20L	100 mm	1
	900/25		1
	900BG/31C	129 mm	1
	892/0	■ 1/4 - ● 1/4	1
	895/1	○ 1/4 - □ 1/4	1
	861LP	● 0,6x4,5-1,2x6,5-1,2x8 mm	3
	861PH	⊕ PH1-PH2-PH3	3
	861PZ	⊕ PZ1-PZ2-PZ3	3
	861PE	○ 2,5-3-4-5-6 mm	5
	861RTX	⊕ T10-T15-T20-T25-T27-T30-T40	7
	900/55Z	⊕ 126 mm	1

867/C52

52 hexagon bits, 10 mm and 2 accessories

2,1 kg 008670901

10mm



52x

250x170x70 mm

	867PE	○ 4-5-6-7-8-10-12 mm
	867PE/L	○ 4-5-6-7-8-10-12 mm
	867XZN	○ M5-M6-M8-M10-M12
	867XZN/L	○ M5-M6-M8-M10-M12
	867TX	⊕ T20-T25-T30-T40-T45-T50-T55
	867TX/L	⊕ T20-T25-T30-T40-T45-T50-T55
	867RTX	⊕ T20-T25-T30-T40-T45-T50-T55
	867RTX/L	⊕ T20-T25-T30-T40-T45-T50-T55
	867/1	○ 10 mm - □ 3/8"
	867/2	○ 10 mm - □ 1/2"

900/C39U

Assortment of 11 gear lock sockets, 21 bits and 7 accessories, in plastic case

009001947

14" 1/4"

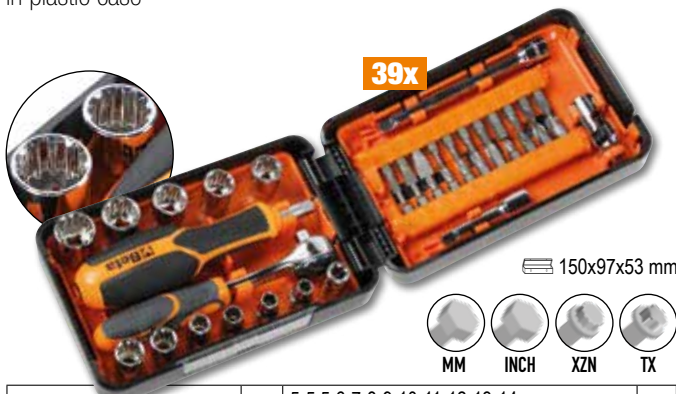

39x

150x97x53 mm



	900U	mm 5-5,5-6-7-8-9-10-11-12-13-14 mm	11
		" 13/64-7/32-1/4-9/32-5/16-11/32-3/8-7/16-15/32-1/2-9/16	
		XZN M6-M8-M10-M12-M14-M16-M18	
		FTX E7-E8-E10-E12-E14-E16-E18	
	900/20	50 mm	1
	900/20L	100 mm	1
	900/25		1
	900BG/31C	129 mm	1
	892/0	■ 1/4 - ● 1/4	1
	895/1	○ 1/4 - □ 1/4	1
	861LP	● 0,6x4,5-1,2x6,5-1,2x8 mm	3
	861PH	⊕ PH1-PH2-PH3	3
	861PZ	⊕ PZ1-PZ2-PZ3	3
	861PE	○ 2,5-3-4-5-6 mm	5
	861RTX	⊕ T10-T15-T20-T25-T27-T30-T40	7
	900/55Z	⊕ 126 mm	1

900/C11

11 hexagon sockets, 20 bits and 8 accessories in metal case

1,2 kg 009000971

14" 1/4"

1/4"



39x







270x120x45 mm

	861LP	● 0,5x3-0,8x5,5-1x5,5-1,2x6,5 mm
	861PE	○ 3-4-5-6-8 mm
	861PH	⊕ PH0-PH1-PH2-PH3
	861TX	⊕ T8-T10-T15-T20-T25-T30-T40
	895/1	○ 1/4" - □ 1/4"
	900	○ 5-5,5-6-7-8-9-10-11-12-13-14 mm
	900/16	□ 1/4 - ■ 3/8"
	900/20	50 mm
	900/21	150 mm
	900/25	
	900/42	
	900BG/31	177 mm
	900/55	⊕

902A/C22

3,5 kg **009020807**

Assortment of 22 hexagon sockets and 6 accessories, in metal case

1/4"		900	⊙ 5-5,5-6-7-8-9-10-11-12-13 mm
		900/20	50 mm
		900/25	
1/2"		920A	⊙ 10-13-14-15-17-18-19-22-24-27-30-32 mm
		920/21	125 mm
		920/25	
		920/55	









420x185x60 mm

910A/C16

2,4 kg **009100936**

Assortment of 16 hexagon sockets and 5 accessories in foam tray, in metal case

	910A	⊙ 6-7-8-9-10-11-12-13-14-15-16-17-18-19-21-22 mm	3/8"
	910/21	125 mm	
	910/22	250 mm	
	910/25		
	910/42	210 mm	
	910/55		









335x145x60 mm

920A/C17M

5 kg **009200924**

Assortment of 17 hexagon sockets and 5 accessories in foam tray, in metal case

	920A	⊙ 10-11-12-13-14-15-16-17-18-19-20-21-22-24-27-30-32 mm	1/2"
	920/21	125 mm	
	920/22	255 mm	
	920/25		
	920/42	305 mm	
	920/55		









420x185x60 mm

928A/C12

13 kg **009280955**

Assortment of 12 hexagon hand sockets and 5 accessories, in metal case

	928A	⊙ 22-24-27-30-32-34-36-38-41-46-50-55 mm	3/4"
	928/21	200 mm	
	928/22	380 mm	
	928/25		
	928/42	450 mm	
	928/55		



530x220x80 mm

BETA'S RANGE OF RATCHETS

BETA'S RANGE OF RATCHETS HAS BEEN CHANGED AND EXPANDED:
CHOOSE THE MODEL THAT SUITS YOUR NEEDS BEST!



Ratchet with up to **72 teeth: take-up angle of 5°** for jobs in small spaces. 17-tooth serration, including 11 always in grip.



Minimum head size for easier access. Phosphated square drive.



One-handed reversal.



Hand pressure on the ratchet head does not cause any accidental reversal or release of the socket.

The versions with 1/2" and 3/4" square drives rely on approximately 6% weight reduction, for optimal handling and increased ease of use, without affecting sturdiness or performance.

NEW DESIGN INNOVATIVE MATERIALS FOR TOP PERFORMANCE

STRAIGHT LEVER

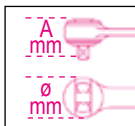

	L mm	Ø mm	A mm	■	Teeth	📄
900/55	127	25	29	1/4"	48	009001155
910/55	207	31	33	3/8"	72	009101155
920/55	271	40	41	1/2"	72	009201155
928/55	504	58	59	3/4"	72	009281155

- 1 Straight lever:** the pressing process originates from a semi-finished product with a round cross-section, specially designed to minimise inner tension, thus resulting in optimal performance
- 2** Slim, ergonomic bi-material handle
- 3** Hanging hole on handle



BENT LEVER

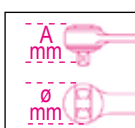

	L mm	Ø mm	A mm	■	Teeth	📄
900E/55	125	26	25	1/4"	48	009001255
910E/55	204	31	33	3/8"	72	009101255
920E/55	267	40	41	1/2"	72	009201255

EASY ACCESS TO SMALL SPACES

- 1 Bent lever** with raised handle compared to worktop, for increased comfort and ease of use in small spaces.
- 2** Slim, ergonomic bi-material handle
- 3** Hanging hole on handle

NEW

TORQUE WRENCH ZERO-RESET THAT DOES NOT REQUIRE RELEASING TENSION



Even if tension is not released, the number of cycles, durability and tightening accuracy as required by reference standards are guaranteed.

The Zero-Reset torque wrench was entirely designed and developed in-house and is manufactured at Beta Utensili's factories in Italy, using 100% Italian-made parts.

ZERO-RESET TECHNOLOGY:

Based on higher-performance materials and improved heat treatment of both the spring and the component parts of the adjustment system, the wrench no longer requires releasing tension after use.

EASY SETTINGS:

The graduated vernier scale allows minimum interval fractions to be set up (in tenths of Nm).

IMPROVED VISIBILITY:

Double graduation in Nm for clearer, simpler torque visibility.



666

ZERO-RESET click-type torque wrenches with reversible ratchets, for right-hand tightening, torque accuracy: ± 3%

UNI EN ISO 6789 **1/4"** **3/8"** **1/2"**



	Nm	■	▤▤▤▤	L (mm)	g	📄
666/2	5÷25	1/4"	0,05	273	395	006660702
666/2X	5÷25	3/8"	0,05	273	405	006660703
666/5	10÷50	3/8"	0,25	342	680	006660705
666/10	20÷100	3/8"	0,25	385	760	006660710
666/10X	20÷100	1/2"	0,25	385	770	006660711
666/20	40÷200	1/2"	0,5	471	1020	006660720
666/30	60÷300	1/2"	1	600	1270	006660730

667

ZERO-RESET click-type torque wrenches with push-through ratchets, for right-/left-hand tightening, torque accuracy: ± 3%

UNI EN ISO 6789 **1/2"** **3/4"**



	Nm	■	▤▤▤▤	L (mm)	g	📄
667/20	40÷200	1/2"	0,5	471	1035	006670720
667/30	60÷300	1/2"	1	600	1285	006670730
667/40	80÷400	3/4"	1	710	2220	006670740

605E

Click-type torque wrenches with reversible ratchets for right-hand and left-hand tightening torque accuracy: ± 6%



1/4"

	Nm	kgfm	lbf.in	■	L (mm)	▤▤▤▤	g	📄
605E/5	1÷5	0,1÷0,5	11÷47	1/4"	190	0,05	180	006050105
605E/10	2÷10	0,2÷1,0	22÷93	1/4"	190	0,1	180	006050110

UNI EN ISO 6789

666/C2

ZERO-RESET click-type torque wrenches, in bi-material case, 14 pieces, with sockets and extension bars

≡ 335x145x60 mm



1,6 kg

006661002

1/4"

	⊗ 666/2	5÷25 Nm
	○ 900	4÷13 mm
	900/...	50-100 mm
	900/16	
	895/1	

NEW

666/C5

ZERO-RESET click-type torque wrenches, in bi-material case, 16 pieces, with sockets and extension bars

≡ 420x185x60 mm



3 kg

006661005

3/8"

	⊗ 666/5	10÷50 Nm
	○ 910A	8÷19 mm
	910/21 - 910/22	125-250 mm
	910/15	
	910/16	
	895/3	

NEW

666/C10X

ZERO-RESET click-type torque wrenches, in bi-material case, 15 pieces, with sockets and extension bars

≡ 420x185x60 mm



3,5 kg

006661011

1/2"

	⊗ 666/10X	20÷100 Nm
	○ 920A	10÷22 mm
	920/20-920/21	75-125 mm
	920/15	

NEW

666/C20

ZERO-RESET click-type torque wrenches, in metal case, 16 pieces, with sockets and extension bars

≡ 510x180x45 mm



4,5 kg

006661020

1/2"

	⊗ 666/20	40÷200 Nm
	○ 920A	13÷27 mm
	920/20-920/21 920/22	75-125-255 mm
	920/15	

NEW

666/C30

ZERO-RESET click-type torque wrenches, in metal case, 18 pieces, with sockets and extension bars

≡ 620x180x45 mm



6,3 kg

006661030

1/2"

	⊗ 666/30	60÷300 Nm
	○ 920A	13÷32 mm
	920/20-920/21 920/22	75-125-255 mm
	920/16	

NEW

599DGT-AW

Electronic torque wrench, torque and angle readout, with reversible ratchet and wireless data transmission, right-hand (accuracy: ± 2%) and left-hand (accuracy: ± 3%) tightening

UNI EN ISO 6789



- Tightening types: torque, angle, torque + angle
- Dual measurement mode: peak hold and track
- Light indicators, an intermittent sound and tactile feedback inform user that preset torque or angle has been reached
- Last 999 peak torque and/or angle readings can be stored and displayed
- 9 "Preset" modes can be saved and preset
- Key safety lockout
- Wrench can be associated with a certain user via software
- Tightening data traceability. Software allows date and time, tool serial number, set tightening value and reached value to be stored and associated with user ID

- Nonslip bi-material handle
- Wrench + software in 9 languages
- Included: 3 AA - 1.5V batteries, wireless USB key and software USB key
- **Bi-directional wireless data transmission, from wrench to software and vice versa, in mass a posteriori or in real time**
- **Customized data processing software with immediate, easy-to-read OK/NG result and real time display of charts**

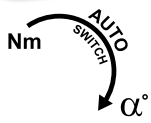

TORQUE + ANGLE

	Nm	kgfm	lbf.ft	■	L (mm)		g	
599DGT-AW/30	6÷30	0,6÷3	4,5÷22	1/4"	410	0,1	800	005990702
599DGT-AW/135	27÷135	2,7÷13,5	20÷100	3/8"	445	1,0	1000	005990713
599DGT-AW/340	68÷340	6,8÷34	50÷250	1/2"	615	1,0	1500	005990734



605DGT/2

Electronic torque wrench with reversible ratchet for right-/left-hand tightening torque accuracy ± 3% (right-hand) ± 4% (left-hand)

- Dual measurement mode: peak hold and track
- Power supply: 1 1.5V AAA battery (included)

175 g 006050302

1/4"



Nm	Kgfm	lbf.in	■	L (mm)	
4÷20	0,4÷2	35÷177	1/4"	210	0,01

UNI EN ISO 6789

677/C

Break-back torque wrenches with push-through ratchets, for right-hand and left-hand tightening, torque accuracy: ±4% in case

The break-back torque wrench, Beta 677, is particularly suitable for heavy-duty use at high torques.



The break-back mechanism informs the user that the set torque has been reached through **the bending of the wrench at the joint by approximately 20°**.

677/C800

UNI EN ISO 6789

3/4"



	Nm	kgfm	lbf.ft	■	L (mm)		kg	
677/C600	120÷600	12÷60	100÷450	3/4"	1059	10	6,0	006770607
677/C800	200÷800	20÷80	150÷600	3/4"	1319	10	6,7	006770612
677/C1000	300÷1000	30÷100	200÷750	3/4"	1554	20	7,4	006770616

584

Slip-torque screwdriver, for right-hand tightening, torque accuracy: +/-6%



UNI EN ISO 6789



	Nm	gfm	⌀	▬▬▬	g	📦
584/1	0,2±1	20±100	1/4"	0,01	266	005840201
584/5	1÷5	100±500	1/4"	0,1	346	005840206
584/10	1÷5	500±1000	1/4"	0,1	349	005840210



584/C31

Assortment of 1 torque screwdriver, 8 hi-torque hexagon nut spinners, 20 bits and 2 accessories

1,3 kg

005840931

	584/5	1÷5 Nm
	900	⌀ 4-5-5,5-6-7-8-9-10 mm
	860LP	⌀ 0,6x4,5-1x5,5-1,2x6,5 mm
	860PH	PH1 - PH2 (x2) - PH3
	860PE	⌀ 2-2,5-3-4-5 mm
	860TX	T9-T10-T15-T20-T25-T27-T30-T40
	882P/80	80 mm
	892/0	● 1/4 ■ 1/4



1/4"

270x120x45 mm

581/5

Slip-torque screwdriver, ungraduated, for right-hand tightening, torque accuracy: +/-6% (to set torque values, use item 680)



005810006



Nm	gfm	⌀	UNI EN ISO 6789
1÷5	100±500	1/4"	

610X/4

Cross torque wrench, has been specially designed for tyre shops; for right-hand tightening with 4 preset torque values: 90 - 100 - 110 - 120 Nm.



006100200

1/2"

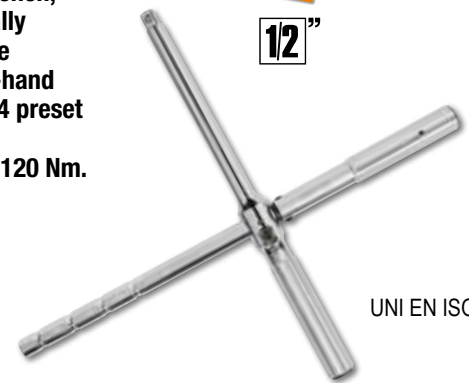

UNI EN ISO 6789



NEW

601C

Digital angle indicator

006010100

- For tightening screws to values set by measuring torsion angle
- Complete with buzzer and LED indicators informing user that preset angle has almost or finally been reached
- For right-hand and left-hand tightening
- Angle accuracy: +/-2°
- Resolution: 0.1°
- Up to 9 angle values can be preset
- Up to 50 measurements can be stored
- Supplied in an ABS case
- Power supply: 2 AAA-size batteries (included)



601CA

Digital torque and angle indicator

006010120

- Allows torque and angle tightening
- For right-hand and left-hand tightening
- Reading scale in Nm/ft.lb/in-lb/kg.cm/degrees
- Torque accuracy: +/- 4% of set value - Angle accuracy: +/- 2°
- Complete with buzzer and LED indicators informing user that preset angle or torque has almost or finally been reached
- Up to 9 torque or angle values can be preset
- Up to 50 measurements can be stored
- Power supply: 2 AAA-sized batteries (included)



□	■	Nm	▬▬▬
1/2"	1/2"	40±200	0,1



1150HPC



Heavy duty universal pliers with cutting edges made of sintered steel

- The decentralized pin allows the fulcrum to be closer to the cutting point, thereby resulting in an improved lever effect.
- Perfect alignment of the nose and the thin profile allow the pliers to be used in very small areas.
- The body of the pliers is made of a reliable molybdenum steel which has been heat treated in order to be flexible and resistant so as to guarantee a safe grip in any moment.



PATENTED
ABSOLUTELY
GROUNDBREAKING
REMARKABLE
CUTTING CAPACITY



Shearing stress - static test =	-73%	
Average life of cutting edges = (test ISO 5744)	+127%	
Hardness of M2 steel cutting edges =	65HRC	

1169BM/D3



Set of 1 combination pliers, 1 long needle nose pliers and 1 diagonal cutting nippers



1169/D3



Set of 1 combination pliers, 1 long needle nose pliers and 1 diagonal cutting nippers



1169N/D4



Set of 1 heavy-duty combination pliers, 1 long needle nose pliers, 1 cutting nippers, chrome-plated, and 1 slip joint pliers with boxed joints, phosphated



NEW

1047N



THE SLIP JOINT PLIERS WITH PUSH BUTTON ALIGNMENT WITH EXCLUSIVE JAW ADJUSTMENT AND AUTOMATIC LOCKING SYSTEM

DIN ISO 8976

- 1** Tapered head for easier access to small areas
- 2** Induction hardened teeth for increased durability. Tooth geometry and angle designed for effective, safe hold.
- 3** Adjustable up to 23 positions in the 250-mm-long size
- 4** Ease of handling and comfort, based on the triangular section of the handles, for an enlarged contact surface and reduced applied work effort
- 5** Nonslip PVC coated handles



PATENTED MECHANISM FOR JAW ADJUSTMENT AND AUTOMATIC LOCKING



The exclusive push button system allows the pliers to be opened, closed and used with one hand.

1047N

	L mm	A Max mm	L1 mm	S mm	g	
1047N 180	180	34	30	6	216	010470018
1047N 250	250	42	37	8	394	010470024
1047N 300	300	52	43	9	524	010470030

1048N

Slip joint pliers, slip-proof PVC coated handles

- Triangular section grip for a more comfortable contact surface
- Tapered head allowing access to small spaces
- Case-hardened nail for improved wear resistance
- The handles coated with innovative slip-proof PVC ensure a secure grip.
- Phosphated finish
- Made from chrome-vanadium steel

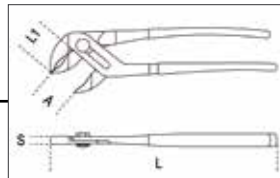

DIN ISO 8976



	L mm	A Max mm	L1 mm	S mm	g	
1048N 175	175	36	31	11	189	010480910
1048N 250	250	46	38	13	354	010480915
1048N 300	300	60	44	14,8	554	010480920
1048N 400	400	96	81	19	1180	010480940

1047N/D3

010470053

Set of 3 slip joint pliers



PROMO

NEW

1048N/D3

010480923

Set of 3 slip joint pliers



PROMO

1048VN

Slip joint pliers, boxed joints, with orange lacquered finish



	L mm	A Max mm	L1 mm	S mm	g	
1048VN 175	175	36	31	11	189	010480111
1048VN 250	250	46	38	13	354	010480116
1048VN 300	300	60	44	14,8	554	010480121

1052

Adjustable self-locking pliers, concave jaws



	L mm	ø Max mm	g	
1052/140	140	22	175	010520014
1052/190	190	36	360	010520019
1052/240	240	42	590	010520024
1052/300	300	55	900	010520030

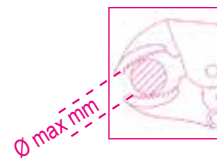

1031/S4

Set of 4 circlip pliers



1032 180 mm
○ 19 ÷ 60 mm

1036 175 mm
● 19 ÷ 60 mm

1038 175 mm
● 19 ÷ 60 mm

1034 170 mm
○ 19 ÷ 60 mm

1199ESD/D3

Set of 1 flat, long nose pliers, 1 diagonal axial cutting nippers and 1 semi-flush cutting nippers, ESD



1190ESD

1188ESD

1172ESD



1009L/DP-S2

Set of 2 extra-long, knurled double swivel nose pliers

- Double swivel
- Suitable for jobs in hard-to-access areas



L 340 mm

1009L/D

1009L/DP



1370

Mechanic's hammers wooden shaft



UNI 7778 DIN 1041
HICKORY

	g	g	
1370/300	300	439	013700053
1370/500	500	669	013700055
1370/800	800	949	013700058
1370/1000	1000	1180	013700060
1370/1500	1500	1722	013700065
1370/2000	2000	2181	013700070

1370T

Mechanic's hammers fibre shaft



	g	g	
1370T/300	300	452	013700630
1370T/500	500	663	013700650
1370T/800	800	1017	013700680
1370T/1000	1000	1279	013700700
1370T/1500	1500	1740	013700750

1390

Soft face hammers, wooden shaft



UNI 7784

	Ø mm	g	
1390/22	22	134	013900022
1390/28	28	230	013900028
1390/35	35	365	013900035
1390/45	45	689	013900045
1390/60	60	1462	013900060

32AU

000320160

Automatic centre punches

- Strength of impact can be adjusted through knurled part, up to 50 kg
- Centre punching operations can be performed with one hand.



31/B6N

000310024

Set of 6 pin punches

in roll-up wallet made of durable polyester

Ø 2-3-4-5-6-8 mm



1380T

Mason club hammers, fibre shafts



	A mm	L1 mm	g	
1380T 800	35	85	800	013800308
1380T 1000	40	100	1000	013800310
1380T 1250	42	110	1250	013800312
1380T 1500	45	120	1500	013800315
1380T 2000	49	120	2000	013800320

963

009630001

Pry bar with pointed and flat bent ends



412/SP25

Set of 25 twist drills, HSS, with cylindrical shanks in case

Ø 1÷13 x 0,5 mm

R ≤ 800 N/mm²
HV ≈ 750÷820
DIN 338



≡ 110x190x55 mm



004120425

437U/09

Assortment for repairing damaged threads in metal case

M5X0,8
M6X1,0
M8X1,25
M10X1,5
M12X1,75

≡ 370x230x55 mm



2 kg 004370550

450/C21

Assortment of holesaws and accessories for industrial use

	450	Ø 19-22-29-35-38-44-51-57-64-76 83-92-95-105-114 mm
	450AL	/1 - /2
	450PA	/1 - /2
	450PR	
	450AD	



21x

Co8%

≡ 420x280x60 mm

7 kg 004500315

446/C110

Assortment of 105 chrome-steel taps and dies, metric thread, and 5 accessories for car repair jobs, in wooden case

435/0 444/1 436/1
435/3 444/2



≡ 500x337x60 mm

8,1 kg 004460060

430 M mm	433 M mm	440/440A M mm	441/441A M mm
2x0,4	6x0,75 - 7x0,75	2x0,4	6x0,75 - 7x0,75
3x0,5	8x0,75 - 8x1	3x0,5	8x0,75 - 8x1
4x0,7	9x0,75 - 9x1	4x0,7	9x0,75 - 9x1
5x0,8	10x0,75 - 10x1	5x0,8	10x0,75 - 10x1
6x1	10x1,25 - 11x0,75	6x1	10x1,25 - 11x0,75
7x1	11x1 - 11x1,25	7x1	11x1 - 11x1,25
8x1,25	12x0,75 - 12x1	8x1,25	12x0,75 - 12x1
9x1,25	12x1,25 - 12x1,5	9x1,25	12x1,25 - 12x1,5
10x1,5	14x1 - 14x1,25	10x1,5	14x1 - 14x1,25
11x1,5	14x1,5 - 16x1	11x1,5	14x1,5 - 16x1
12x1,75	16x1,5 - 18x1,5	12x1,75	16x1,5 - 18x1,5
14x2		14x2	
16x2		16x2	

1599F

Parallel bench vices, forged

Fully steel cast. Milled and hardened jaw surface. Front opening. High clamping depth.

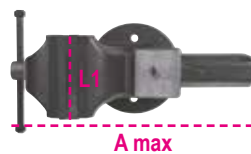

	L mm	BxH mm	Ø mm	A max mm	
1599F/100	100	92x46	11	125	015990100
1599F/125	125	108x54	13	150	015990125
1599F/150	150	125x62	13	200	015990150
1599F/175	175	140x70	15	220	015990175

Beta

POWERTOOLS

POWER TOOLS

1972/K12V-10

019720112

Ultracompact drill, 12V

- Double mechanical speed with steel gears and 20-position clutch
- Torque up to 30 Nm and 1300 rpm (400 rpm in 1st gear); drills diameters up to 10 mm in steel and 20 mm in wood
- 2Ah batteries and charge indicator on drill body
- Ergonomic nonslip handle
- Front LED
- 10-mm autochuck
- Belt clip (right/left side)
- Selector switch, screwing-unscrewing-locking modes (for transportation)
- **Supplied in a hard case with 2 lithium ion batteries (2 Ah) and quick charger (50 min)**



Ultracompact: no more than 170 mm in length

Ultralightweight: no more than 1.1 kg, with battery, and perfectly balanced

1956 115-750W

019560011

Angle grinder for discs Ø 115 mm

- **Powerful motor (750 W)**
- Nonslip ergonomic handle for increased comfort and safety
- Lowered head that allows working in confined spaces
- Extremely lightweight (weighs no more than 1.8 kg)
- Protection against accidental activation
- Additional handle that can be mounted on both sides
- Tool-less disc cover (quick release)
- Spindle lock device for quick disc changes
- Lock-on/off slide switch
- Air vents protected against dust infiltration and providing optimal cooling performance
- Service wrench included



- Free speed: 11,000 rpm
- Tool spindle thread: M14
- Tangle-free cable length: 4 m

1984/K600+BORSA

019840038

20V impact wrench kit, 600 Nm + technical fabric bag

1984/K600

Brushless 20V reversible impact wrench, 600 Nm
Supplied in a hard case with 2 batteries (4 Ah) and quick charger.

1984/K1200+BORSA

019840039

20V impact wrench kit, 1,200 Nm + technical fabric bag

1984/K1200

Brushless 20V reversible impact wrench, 1,200 Nm,
Supplied in a hard case with 2 batteries (6 Ah) and quick charger.



Max 600 Nm



INCLUDED FOR YOU
 technical fabric bag C9PT



1/2" male square drive, 3 different torque settings in screwing mode, 2 in unscrewing mode.
 Digital BRUSHLESS motor for significantly improved performance: increased power, reduced energy consumption, extended motor service life, improved power supply from button.

Max 1200 Nm



NEW

363

Heavy duty pipe wrenches made from light alloy



	L mm	Ø "	Ø mm	
363 350	350	2" gas	60	003630035
363 450	450	2 1/2" gas	76	003630045
363 600	600	3" gas	90	003630060
363 900	900	5" gas	140	003630090
363 1200	1200	6" gas	165	003630120

376

Pipe wrenches, Swedish pattern, 90° flat jaws



	L mm	Ø "	Ø mm	
376 320	320	1" gas	34	003760032
376 410	410	1 1/2" gas	49	003760041
376 550	550	2" gas	60	003760055
376 630	630	3" gas	90	003760063

1750KG10

10 kg 017500100

Lever-operated grease gun, 10 kg, with high-pressure hose, 2 m

- Complete with swivel fitting, to avoid choking hose
- Die-cast aluminium pump body with check valve

3 different pressure levels available:

- 4 g at 275 bar
- 7 g at 206 bar
- 9 g at 137 bar



1750

017500500

Lever operated grease guns, 500 cc



332

Mini pipe cutter for copper and light alloy pipes



	L mm	Ø mm / "	
332	59	3÷16 1/8"÷5/8"	003320001
332/2	63	3÷28 1/8"÷1"1/8"	003320003

1749A

017490010

Bonding gun, professional model aluminium tube



1749AC

017490005

High thrust gun for chemical binders



RIVETING PLIERS

Ø mm	1741TR						1741						1740B 280						1740B 330						1741U					
	2,4	3,2	4	4,8	5	6,4	2,4	3,2	4	4,8	5	6,4	2,4	3,2	4	4,8	5	6,4	2,4	3,2	4	4,8	5	6,4	2,4	3,2	4	4,8	5	6,4
ALUMINIUM	•	•	•	•	X	X	•	•	•	•	•	X	•	•	•	•	X	X	•	•	•	•	•	•	•	•	•	•	•	•
STEEL	•	•	•	X	X	X	•	•	•	•	•	X	•	•	•	•	X	X	•	•	•	•	•	•	•	•	•	X	X	X
INOX	•	•	•	X	X	X	•	•	•	X	X	X	•	•	•	•	X	X	•	•	•	•	•	•	•	•	•	X	X	X

1741TR

017410410

Riveting pliers with rotating head, supplied with 4 interchangeable nozzles

- Head can be rotated 360°, for hardly accessible areas to be reached.



1740B

Compact heavy-duty riveting pliers

- Ultracompact, extremely sturdy
- Safety nail container included



**3 JAWS:
IMPROVED
RIVET GRIP**



	L mm	g	
1740B 280	280	650	017400280
1740B 330	330	1000	017400330

1741

017410003

Riveting pliers with 4 interchangeable nozzles



**COMPACT
AND LIGHTWEIGHT**

1741U

017410450

Ultra compact riveting pliers with adjustable force with 4 interchangeable nozzles



**3 JAWS:
IMPROVED
RIVET GRIP**

WIRELESS RECHARGEABLE



	LUMEN	BATTERY	CHARGING TIME	BATTERY LIFE	IP/IK
1833XSW	80 - 250 (LED SMD)	3,7V 700 mAh, 2.59 Wh Li-ion	2h 1839BRW or cable	2 - 8h	IP54; IK07
1833MW	5 - 30 - 400 - 1000 (LED SMD)	3,7V 2.600 mAh, 9.62 Wh Li-ion	6h 1839BRW 4h cable	2- 200h	IP68; IK07
1836AW	30 - 200 - 400 (Main light LED COB) 400 (spot LED COB)	3.7 V, 1500 mAh, 5.55 Wh Li-ion	2,5h 1839BRW or cable	Main light: 4-18h Spot: 4h	IP65; IK07
1836BW	225 - 250 - 500 (Main light + spot 500 lumen LED SMD) 20 (Red light LED SMD)	3.6V, 3000 mAh Li-ion	6h 1839BRW 4,5h cable	Main light + spot : 2.5h Main light: 4h Spot: 4h Red light: 18h	IP65; IK06

1833XSW

LED inspection torch, wireless rechargeable

- Magnets on base and back
- Belt clip
- USB cable included



 018330011

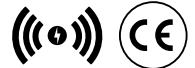

1833MW

High-brightness LED torch, wireless rechargeable

- Four brightness settings
- Magnet on back
- USB cable included



 018330013

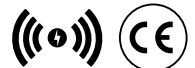

1836AW

Rechargeable wireless LED headlamp, dual brightness

- Dual light emission
- USB cable included



 018360051



1836BW

Rechargeable LED headlamp, with red light and contactless ON/OFF sensor, wireless

- Contactless ON/OFF sensor
- USB cable included
- Battery level indicator



 018360201



NEW

WIRELESS RECHARGEABLE



	LUMEN	BATTERY	CHARGING TIME	BATTERY LIFE	IP/IK
1838/13LED-W	430 (frontal LED SMD) 90 (spot LED SMD)	3,6V, 6.000 mAh Li-Ion	10,5h 1839BRW 5h cable	Main light + spot : 4h Main light: 5h Spot: 10h	IP65; IK07
1838SW	250 - 500 - 1000 (frontal LED COB) 200 (spot LED SMD)	3.6V 3.350 mAh Li-ion	6,5h 1839BRW 4,5h cable	Main light: 2-8h Spot: 7h	IP65; IK07
1838POCKET	160 - 400 - 800 (Main light LED COB) 250 (spot LED SMD)	3.7V 2.600 mAh Li-ion	4,5h 1839BRW 4h cable	Main light: 3-9h Spot: 4,5h	IP65; IK07

1838/13LED-W 018380112

Rechargeable high-brightness LED lamp, wireless

- Dual light emission
- Supplied with USB-C cable
- Battery level indicator
- Swinging hook
- 1 magnet on base
- 2 side magnets

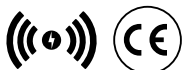

NEW

1838SW 018380142

Rechargeable, articulated LED inspection lamp and wireless charging

- Dual light emission
- Base can be rotated 180°
- Nonslip rubber body
- Double swinging hook
- Magnets on base and back
- USB cable included



1838POCKET 018380080

Articulated pocket LED spotlight, with dual light beam and wireless charging

- Dual light emission
- Lighting angle:
 - main light: 160°
 - spot light: 18°
- Can be rotated 210°
- Nonslip rubber body
- Magnetic base
- Supplied with a USB cable



1839BRW 018390002

Wireless charging base, compatible with 1833XSW, 1833MW, 1836AW, 1836BW, 1838/13LED-W, 1838SW, 1838POCKET inspection lamps

- Two charging positions with magnetic connection, for simultaneous use
- With pull-out support for wireless mobile phone charging
- Charging status LED indicator
- Max. input: 10W x2
- Input: AC 100-240V 50/60Hz
- Output: DC 12V 1.5A
DC 9V 2A
DC 5V 3A
- USB-C port
- IP20
- IK07



- **Can be hung on wall through:**
3 strong magnets on back
2 screw holes



KIT WIRELESS (📶)

Wireless technology means one of the latest innovations in the work lighting industry and provides a convenient, modern solution to every professional's requirements.

1839W/P1

018390800

Kit of wireless lamps 1833MW, 1836AW, with compatible charging base 1839BRW

- High-brightness LED torch **1833MW**, wireless rechargeable
- LED headlamp, wireless rechargeable, with dual light emission **1836AW**
- Wireless charging base **1839BRW** compatible with kit lamps



PROMO



1839W/P2

018390805

Kit of wireless lamps 1838SW, 1838POCKET, with compatible charging base 1839BRW

- Rechargeable, articulated LED inspection lamp **1838SW**, wireless rechargeable
- Articulated pocket LED lamp **1838POCKET**, adjustable, with dual light beam, wireless rechargeable
- Wireless charging base **1839BRW** compatible with kit lamps



NEW

1838FLASHPRO

018380301

Rechargeable, ultracompact spotlight, designed to provide the best solution for each use

- **3 light intensities:** LED SMD 1200 - 1000 - 800 lumens
- Rechargeable battery: Li-Ion, 3.6V, 10.000 mAh
- Can be charged via power supply with USB-C port
- Supplied with USB-C cable and power supply
- Battery level indicator
- Charging time: 7,45 h
- Battery life: 8.5 h
- IP65
- IK07



NEW

1838AM

018380400

Rechargeable LED inspection lamp

- **Double light emission:** front: LED COB, 60-700 lumens, can be adjusted with potentiometer spot (head): LED SMD, 120 lumens, ON-OFF switch
- Rechargeable 3.6V 2600mAh Li-ion battery
- With USB-C port
- Supplied with 100-240V / 50-60Hz charger
- Charging time: 4h
- Battery life: front: 2.5-16h spot (head): 10h
- 3-LED battery level indicator
- Magnetic base (with neodymium magnet), can be rotated 90°
- Swivel base hook
- Articulated, can be rotated 180° (± 90° compared to axis)

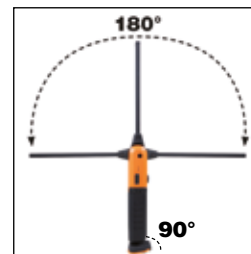

1838SLIM

018380221

Rechargeable, articulated slim 3-LED inspection lamp

- **Triple light emission:**
 - front: 100/200 lumens
 - back: 180 lumens
 - spot (head): 80 lumens
- Magnetic base
- Charging time: 2.5 h
- Battery life: 2-4 h/ spot 3 h
- IP54; IK07
- L 307 mm



1838F

018380040

Rechargeable magnetic LED lamp with flexible head and double light emission

- **Double light emission:**
 - main: 32 light intensities
 - LED COB 50 - 500 lumens
 - spot (head): LED SMD, 120 lumens
- Rechargeable battery: Li-Ion 3.7 V, 2600 mAh
- Charge with USB-C port
- USB-C cable included
- Charging time: 4h
- Battery life:
 - main: 2h
 - spot: 9.5h
- Magnet on base
- Hook can be bent at 90°
- 3-LED battery level indicator
- IP54; IK07



NEW

1838CLAMP

018380310

Rechargeable clamp spotlight with adjustable light beam and 4 light intensities

- 4 light intensities:
 - 1600 lm - Ultra high mode
 - 700 lm - High mode
 - 300 lm - Low mode
 - 100 lm - Eco mode
- Rechargeable battery: Li-Ion 3.7 V, 5200 mAh
- Can be charged with USB-C cable (included)
- Can be rotated 360°
- Charging time: 4h
- Battery life:
 - 3h - Ultra high mode
 - 5h - High mode
 - 8.5h - Low mode
 - 24h - Eco mode
- 3-LED battery level indicator
- With built-in clamp, can be easily clamped everywhere
- 1 magnet on back
- IP65; IK07



NEW

1838PN

018380008

Rechargeable LED pen light

- **Dual light emission:** main and spot
- 3 light intensities:
 - main COB LED 350 - 175 lumens
 - spot: SMD LED 120 lumens
- Rechargeable battery: Li-Ion 3.7 V, 1600 mAh
- Charging time: 2.5h
- Battery life:
 - main: 6/3h
 - spot: 6h
- Magnetic base
- Belt clip/magnetic pocket
- IP65; IK07
- USB-C cable included



1838COMPACT

018380011

Rechargeable, compact LED lamp

- **Dual light emission:** main and spot
- 3 light intensities:
 - main COB LED 300 - 120 lumens
 - spot SMD LED 150 lumens
- Rechargeable battery: Li-Ion 3.7 V, 1500 mAh
- Charging time: 2.5h
- Battery life:
 - main: 7/3.5h
 - spot: 6h
- Belt clip/pocket
- IP65; IK07
- USB-C cable included



16091/C6

016090300

Crimping pliers with 6 interchangeable dies

6in1



**ADJUSTABLE,
WITH QUICK-RELEASE
MECHANISM**

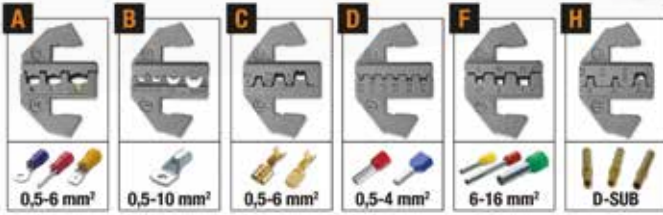

6 different types of dies:

- for pre-insulated ring, ferrule and quick male terminals, 0.5÷6 mm²
- for non-insulated terminals, 0.5÷10 mm²
- for non-insulated female and male terminals, 0.5÷6 mm²
- for pre-insulated tubular terminals, 0.5÷4 mm²
- for pre-insulated tubular terminals, 6÷16 mm²
- for non-insulated terminals, type D-SUB

NEW

1149F

011490010

Front wire stripping pliers with cutting blade, self-adjusting

- Self-adjustment to wire diameters
- Adjustable stripping length
- Insulating cutting pressure adjustment
- Built-in cutting device



0,2÷6 mm²

1128 X-PRO

BM1325

Electrician's scissors, short blades, with wire stripping groove

- Stainless steel blades
- Wire stripping groove
- Microteeth on one side



NEW

1128 X-PRO EVO

BM1330

Electrician's scissors, short blades, with wire stripping groove

- Stainless steel blades
- Wire stripping groove
- Microteeth on one side



NEW

1609B

4,2 kg

016090101

Mechanical crimping pliers

- For noninsulated copper terminals, 10÷120 mm²
- Antislip rubber handle
- Internal "H" section pin for unparalleled punch smoothness
- Made from burnished steel

10÷120 mm²



L 600 mm

1608

016080001

Crimping pliers for insulated terminals, with pressure regulator

0,5÷6 mm²



1606T

016060005

Crimping pliers for tubular terminals, 4-sided crimping

0.1÷10 mm²



1691MG

Measuring tapes with fixed magnets

- Shock-resistant ABS casings
- Steel tapes
- Precision class: II



	L m	S mm	
1691MG/5	5	25	016910405
1691MG/8	8	25	016910408
1691MG/10	10	25	016910410

1687/S4

016870150

Set of 4 engineer's precision scribes, with handles



1651DGTB

Digital vernier, reading to 0.01 mm

- Screw slider locking
- Mm/inch conversion
- Zero setting at any position
- Square depth rod up to 300 mm
- In hard plastic case

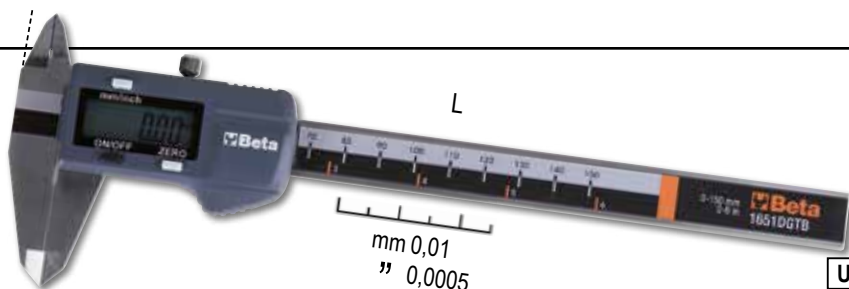

	A Max mm	L mm	B mm	G mm	
1651DGTB 150	150	235	40	0,01-0,0005	016510211
1651DGTB 200	200	285	50	0,01-0,0005	016510212
1651DGTB 300	300	400	60	0,01-0,0005	016510213



1650

Sliding gauge made from hardened stainless steel

- Reading to 0.05 mm
- Spring locking

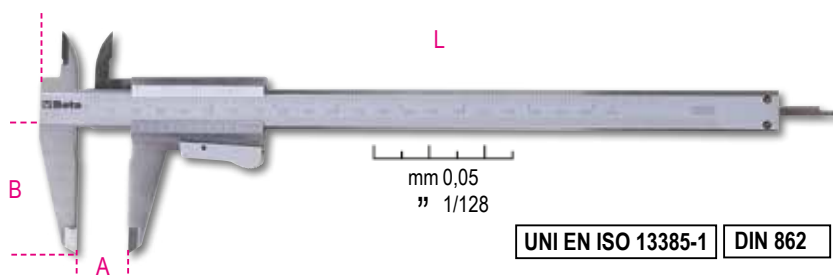

	A Max mm	L mm	B mm	G mm	
1650/150	150	235	40	0,05-1/128	016500001
1650/200	200	290	49	0,05-1/128	016500002

1706DGT

017060011

Digital depth gauge for tyre threads



L mm	A Max mm	L1 mm
112,5	25	60

1693M 80

016930080

Laser distance meter, multipurpose, 80 m

Measurements:

- Single distance measurement
- Continuous measurement or minimal measurement

Functions:

- Addition/subtraction
- Area measurement
- Volume measurement
- Indirect measurement (Pythagorean measurement)
- Tilt measurement
- Auto off feature
- Soft cloth case (included)
- Battery life: up to 4,000 measurements

Technical data:

- Measurement range: 0.05 ÷ 80 m (0.2 in ÷ 229ft)
- Scale selection: m, in, ft
- Measurement accuracy: ±1.5 mm (± 0.06 in)
- Laser class: 2
- Max. storage: 99 units
- Batteries: AAA 2 x 1.5V



80 m



IP54



1760/RMS

017600020

Industrial digital multimeter accurate and sturdy, in a 6-mm co-moulded shell, with antislip, shockproof outerrubber part

- Protection up to 1000V
- Tested for accidental falls up to 2 m
- Protected inlets
- Autoranging
- Large direct reading display, backlit, blue
- K type temperature probe (included)
- Self-power down
- Rubber terminal base for enhanced operating comfort
- Double insulated terminals, 1000V, 1 m long
- Supplied in a soft case
- CAT IV 600V/ CAT III 1000V
- Actual effective value TRUE RMS



IP67



	Measuring range	Base accuracy
AC/DC voltage	110mV – 600V ±0.8%	- ±2% rdg
AC/DC current	110µA – 10A ±1.5%	- ±2% rdg
Resistance	110Ω – 40MΩ ±1.2%	- ±2.5% rdg
Capacity	11nF – 40mF ±5%	- ±10% rdg (up to 11mF)
Frequency	1100Hz – 110 MHz ±1.2%	- ±1.5% rdg
Temperature	-32°C – +1000°C ±3%	- ±5% rdg
Diode test	3V DC ±10% rdg	
Continuity test	<30 Ω	

1760S

017600022

Compact digital multimeter

- IP40 protection
- Autoranging
- Large direct reading display, backlit, blue
- Self-power down
- Low battery indication
- Supplied in a soft case
- CAT III 600V
- TRUE RMS (actual effective value)



IP40



Measurable parameters:

DC voltage: 200 mV-2/20/200/600V
 AC voltage: 100/600V
 DC current: 200 mA-10 A
 AC current: 0,01-10 A
 Resistance: 200Ω - 2/20/200 kΩ - 2 MΩ
 Diode test: 0.4 ÷ 0.7
 Power supply: 2 1.5V batteries, type AAA

1760TMC

017600710

Infrared thermal camera

Compact thermal camera for contactless temperature measurement, suitable for applications in building, mechanical, electric installation and heating industries.

TEMPERATURE RANGE
-20 ÷ +600 °C



IP54



- LCD TFT display, 2", 240x320
- Sensor, 32x32 pixels
- Acquisition frequency 7Hz
- Thermal sensitivity <347mK
- Automatic acquisition of hot and cold spots
- Camera for acquisition of images in BMP format (max. 100 images)
- Adjustable emissivity
- Power supply: 3 alkaline AAA batteries
- USB interface
- IP54
- Temperature range: -20 °C ÷ +600 °C
- Infrared band: 6.5÷14µm
- Visible/infrared image fusion: 0.5; 1; 2m
- Alarm function, selecting acceptable maximum and minimum temperatures



1778MT

MULTIPURPOSE TOOL COMPLETE WITH BITS AND SHEATH



1778MT

017780055

Multi-tools complete with bits and sheath

9 tools for a total of 22 functions:

- Combination pliers
- Large blade
- Corrugated blade
- Hacksaw frame
- File
- Tin/Bottle opener
- Scissors
- Bit holder
- Screwdriver for cross head Phillips® screws



SUITABLE FOR EVERY SITUATION!



11 bits + socket + tweezers



Ruler 100 mm + Ruler, 4"



Easy pull-out of tools



Tool unlock buttons

1726N

017260040

Coated hacksaw frame, blade attachment system in handle

- Bi-material coated aluminium alloy handle
- Blade compartment
- Blade can be tilted up to 55° and 90°, with built-in attachment system



NEW

1772M

017720040

Safety utility knife with retractable blade, supplied with 4 blades

- Blade retracts through an automatic spring mechanism
- Die-cast alloy body
- Staple remover built into handle



1729MF

017290500

Multi-purpose saw

- 24 TPI metal blade
- 6 TPI plasterboard blade
- double 11 TPI plastic and 16 TPI wood blade



1771BM

017710050

Utility knife, 18 mm, 6 spare blades

- Nonslip bi-material handle
- Automatic blade loading
- Blade locking nut for maximum blade stability under stress conditions
- Nonreturn safety slider
- Automatic blade loading



1778S0S

017780080

Car service knife with window breaking hammer and seat belt cutter features, in case

- With clip and fabric wallet with loop
- Anodized aluminium handle
- Safety blade lock



1128BAX

011280088

Double-acting electricians' scissors, with milling profiles in DLC-coated stainless steel

- High blade surface hardness (resistance to abrasion and wear)
- Low coefficient of friction (smoothness and anti-adherence)
- With articulated plastic case



Profile and mill: designed to enlarge holes on plastic, from 13 to 25 mm.

1128BMX

011280051

Electrician's scissors, straight stainless steel blades, with microteeth

- Straight stainless steel blades
- Wire cutting groove
- Microteeth on one side



1128FXS

011280095

Electrician's scissors, straight stainless steel blades, with microteeth, cable cutting groove and crimping pliers for tube terminals

- Articulated belt hook case
- Bimaterial handles
- Anti-loose pin



Profile mill: designed to enlarge holes on plastic, from 13 to 21 mm.



1128BSX

011280061

Electrician's scissors with graduated milling profiles with case

- Designed to enlarge holes on plastic junction boxes and choke corrugated pipes
- Jointed belt case
- Bimaterial handles
- Anti-loosening pin



1600Q 10

016000010

Eight-way wrench, with articulated joint

- Square 5 / 6-7 / 8-9 mm
- Triangle 5-6-7 / 8-9 / 10 mm
- Alette 3-5 mm
- Hexagon 1/4"
- Male drive 1/4"

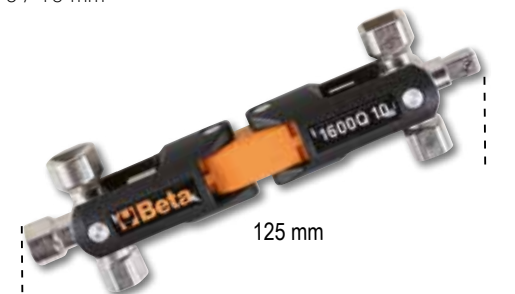

1134S

011340030

Ratcheting cable cutter

- Burnished, with nonslip PVC handles
- **Reduction gear allows high force to be applied with one hand.**



L mm	mm	mm ²
255	32	400



NEW

1134B

011340050

Ratcheting cable cutter

- Burnished, with nonslip PVC handles
- **Reduction gear allows high force to be applied with one hand.**



L mm	mm	mm ²
275	53	500



NEW

NEW

THE IDEAL KIT FOR ELECTRICIANS

1233MQF/D4-FX

012330905

Set of 4 slim screwdrivers with electrician's scissors item 1128FX

• 1233MQF/D4

Set of 4 slim screwdrivers
 1234MQF/LP ● 4x100-5,5x125 mm
 1232MQF ⊕ PH1x75-PH2x100 mm

• 1128FX

Electrician's scissors, straight stainless steel blades, with microteeth, cable cutting groove and crimping pliers for tube terminals



1233MQF/D6

012330606

Set of 6 screwdrivers

1234MQF/LP ● 3x100-4x100-5,5x125 mm
1232MQF ⊕ PH0x60-PH1x75-PH2x100 mm



EN 60900



⚡ 1000 V

Controlled grip zone with triangular palm grip to enable maximum force to be applied. Circular speed zone with textured grip. Precision zone with anti-roll hexagonal section.

NEW

1273MQ/D6

012730851

Set of 6 screwdrivers

1274MQ ● 3x100-4x100-5,5x125 mm
1272MQ ⊕ PH0x60-PH1x80-PH2x100 mm



EN 60900



⚡ 1000 V

1128MQ

011280101

Electrician's scissors, stainless steel blades, with microteeth

⚡ 1000 V

IEC 60900



1169MQ/D2

011690152

Assortment of insulated combination pliers and insulated diagonal cutting nippers



≡ 1150MQ 180 mm

⊥ 1082MQ 160 mm

⚡ 1000 V

EN 60900



920MQ/C16

≡ 5,2 kg

009200917

Set of 9 hexagon sockets, 3 socket drivers for hexagon screws and 4 accessories

	920MQ/A	○ 8-10-12-13-14-17-19-22-24 mm
	920MQ/21	135 mm
	920MQ/22	264 mm
	920MQ/55A	
	920MQ/T	
	920MQ/PE	○ 5-6-8 mm

1 1/2"



16x

⚡ 1000 V

IEC 60900



≡ 420x280x60 mm

1997MQ/GM

Composite insulating gloves

EN 60903
EN 61482

CLASS 0

1000 V



	G	
1997MQ/GM 9	9	019970109
1997MQ/GM 10	10	019970110

1760PT/N

017600155

Voltage and continuity tester, 1000 V



Voltage and continuity tester: accuracy and reliability with up to 1000V power. Equipped with a high-visibility digital screen and a convenient self-test function, the tool ensures both accuracy and reliability in each measurement, which makes it a must-have for every professional.



Features

- Voltage: 24÷1000VAC / 6÷1000VDC
- Bar voltage indicator: 6-12-24-50-120-230-400-690-1000
- Accuracy: ± (3% + 3V)
- Response time: < 1s (09%)
- Maximum absorbed current @1000V: < 3,5mA
- Contact-free voltage detection: > 90VAC
- Phase rotation test: 100÷1000VAC (50/60Hz)
- Phase angle: 120° ±5°
- Continuity test: 0±1.3 MΩ
- Current (continuity test): ≤5 μA
- Pollution level
- Power supply



17600HM/2

017600027

Megohmmeter for high voltage insulating testing



Our megohmmeter is synonymous with technology and accuracy for really professional measurements. With an insulating capacity up to 100 GΩ at 1000V voltage, this instrument is ideal for professional, accurate measurements in all electrical applications.

Particularly suitable for electric and hybrid cars.

Features:

- Insulation test up to 100 GΩ with 1000V voltage
- Large direct reading display, backlit
- Water protection: IP67
- Rubber terminal base for enhanced operating comfort
- Double insulated terminals CAT IV 600V, CAT III 1000V
- Ideal for electric and hybrid cars



	Measuring range	Basic accuracy
AC voltage:	10V - 600V	±(1.5% +5)
DC voltage:	0V - ±600V	±(1.5% +5)
Resistance:	0.01Ω - 200Ω	±(2% +5)
Insulation test:		
@1000V:	0.01Ω - 100GΩ	±(1.5% +5)
Frequency:	1~1KHz	±(0.1% +3)

2115PL-MQ32

021150332

12" Assortment of 32 insulated tools for hybrid cars, in plastic tool box with soft thermoformed tray

Quantity/Description

- 1 1/2" reversible ratchet
- 2 single ring wrenches 10-12 mm
- 1 magnetic bit holder, insulated 1/4"
- 10 set of 10 bits with magnetic bit holder
- T7-T8-T9-T10-T15-T20-T25-T27-T30-T40
- 7 hexagon sockets 8-10-12-13-14-17-19 mm
- 1 1/2" square drive extension bar 125mm
- 1 1/2" square drive extension bar 250mm
- 1 slip joint pliers, boxed joint 250mm
- 1 combination pliers 1000V 180mm
- 1 extra-long bent flat nose pliers 160mm
- 2 screwdrivers for cross head Phillips® screws, 1000V 4.5X80-6X100mm
- 3 screwdrivers for headless slotted screws, 1000V 3X100-4X100-5.5X125
- 1 insulating gloves, made from latex G2
- 1 tool box, long series, made from plastic

- Beta N.**
- 920MQ/55A
 - 89MQ
 - 850MQ
 - 861TX/A10
 - 920MQ/A
 - 920MQ/21
 - 920MQ/22
 - 1048MQ
 - 1150MQ
 - 1164MQ
 - 1272MQ
 - 1274MQ
 - 1997MQ/GM
 - CP15L

1000 V



5100 RSC51-MQ38

051000353

E-mobility service trolley with 38 insulated tools

- ABS reinforced worktop, solid and sturdy
- Multipurpose top with anti-fall edges and 8 holes for accommodating screwdrivers
- 3 drawers (588x367 mm) with ball bearing slides, 70 mm high
- Drawer bases protected by foamed rubber mats
- Each drawer can accommodate up to 4 EVA foam or ABS thermoformed trays
- Front centralized safety lock
- Convenient side screwdriver holder included

- Two built-in side spray can holders
- Large lower shelf protected by an anti-oil and anti-petrol rubber mat
- 4 castors, Ø 125 mm: 2 fixed castors and 2 swivel castors (one with brake)
- Capacity of each drawer: 15 kg, evenly distributed

Quantity/Description

- 7 single open end wrenches, 1000V 10-11-12-13-14-17-19 mm
- 3 single ring wrenches 10-12-13 mm
- 7 bi-hex sockets ○ 8-10-12-13-14-17-19 mm
- 1 3/8" drive, T-handle
- 1 3/8" drive reversible ratchet
- 3 socket drivers for Torx® head screws ○ TX20-TX25-TX30
- 1 3/8" drive extension 125 mm
- 1 slip joint pliers, boxed joint 250 mm
- 1 diagonal cutting nippers 1000V \leq 160 mm
- 1 electrician's scissors 145 mm
- 1 combination pliers 1000V \equiv 180 mm
- 1 extra long flat nose pliers \equiv 160 mm
- 1 extra-long bent flat nose pliers \equiv 160 mm
- 4 screwdrivers for cross head Phillips® screws, 1000V
 ○ 3x60-4,5x80-6x100-8x100
- 4 screwdrivers for headless slotted screws, 1000V
 ● 2,5x75-3x100-4x100-5,5x125
- 1 cable stripping knife, insulated 190 mm

Beta N.	TR
52MQ	M159
89MQ	M159
910MQ/B	M159
910MQ/T	M159
910MQ/55	M159
910MQ/TX	M159
910MQ/21	M159
1048MQ	M161
1082MQ	M161
1128MQ	M161
1150MQ	M161
1162MQ	M161
1164MQ	M161
1272MQ	M161
1274MQ	M161
1777MQ/U	M161



2400 RSC24/6-VEM

024004016

Mobile roller cab with 6 drawers and assortment of 81 repair and maintenance tools for hybrid and electric vehicles



Quantity/Description

- 1 insulating mat
- 4 plastic posts with fillable bases
- 1 multimeter/megohmmeter for high voltage insulation testing
- 1 combination voltage and continuity tester, 12-690V AC/DC
- 1 spare leads for digital multimeters and amperometric clamps
- 1 composite insulating gloves
- 1 plastic barrier chain
- 2 aluminium warning signs
- 2 prohibition signs
- 12 single open end wrenches, 1000V 7-8-10-11-12-13-14-15-16-17-19-22 mm
- 12 single ring wrenches 7-8-10-11-12-13-14-15-16-17-19-22 mm
- 4 socket drivers for hexagon screws ○ 4-5-6-8 mm
- 11 bi-hex sockets ○ 7-8-10-11-12-13-14-15-16-17-19 mm
- 6 socket drivers for Torx® head screws ○ T15-T20-T25-T27-T30-T40
- 2 socket drivers with XZN® profile ○ 8-10 mm
- 1 3/8" drive extension 125 mm
- 1 3/8" drive extension 250 mm
- 1 3/8" drive, T-handle
- 1 3/8" drive reversible ratchet
- 1 electrician's scissors
- 1 slip joint pliers, boxed joint 250 mm
- 1 diagonal cutting nippers 1000V \leq 160 mm
- 1 combination pliers 1000V \equiv 180 mm
- 1 extra long flat nose pliers \equiv 160 mm
- 1 extra-long bent flat nose pliers \equiv 160 mm
- 4 screwdrivers for cross head Phillips® screws, 1000V
 ○ PH0x60 - PH1x80 - PH2x100 - PH3x150 mm
- 4 screwdrivers for headless slotted screws, 1000V
 ● 2,5x75 - 3x100 - 4x100 - 5,5x125 mm
- 1 cable stripping knife, insulated

Beta N.	TR
1995MQ/T	M49
7104 90	
1760/OHM	
1760PT	
1760DGT-R3	
1996MQ/IGM	
7105 6	
7109A	
7109D	
52MQ	M49
89MQ	M49
910MQ/PE	M108
910MQ/B	M108
910MQ/TX	M108
910MQ/XZN	M108
910MQ/21	M108
910MQ/22	M108
910MQ/T	M108
910MQ/55	M108
1128MQ	M161
1048MQ	M161
1082MQ	M161
1150MQ	M161
1162MQ	M161
1164MQ	M161
1272MQ	M161
1274MQ	M161
1777MQ/U	M161



1000 V

RSC24/6-R 8



CAN BE AUTOCLAVE STERILIZED AT 121°

C04TSS/7

Mobile roller cab with seven drawers, made entirely of stainless steel

- 7 drawers (570 x 410 mm) with ball bearing slides;
- 6 drawers, 83 mm high;
- 1 drawer, 170 mm high;
- 4 castors Ø 125 mm 2 fixed and 2 steering (two with brakes);
- Front centralized lock;
- Frame made entirely of stainless steel AISI 304
- Castors, supports, ball bearings, drawer interiors and guides made of stainless steel
- Drawer handles made of aluminium



63 kg **024003077**

n°	Image	Max
6		25 kg
1		30 kg

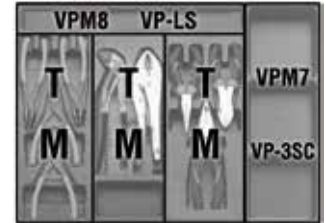
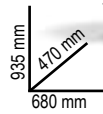
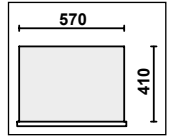

C20TSS

Five-section cantilever tool box, made of AISI 304 stainless steel

It can be used in critical environments - that is, in areas where the minimum contamination level is not permitted - resistant to rust and the main acids, and can be autoclave sterilized at 121°.



450x200x210 mm

4 kg **021203001**

42INOX/SC8

Set of 8 combination wrenches made of stainless steel, with compact support

8-10-11-12-13
14-15-17-19 mm



NEW

000420388

96TINOX/S8

Set of 8 offset hexagon key wrenches, with high torque handles, made of stainless steel

Ø 2,5-3-4-5-6-7-8-10 mm

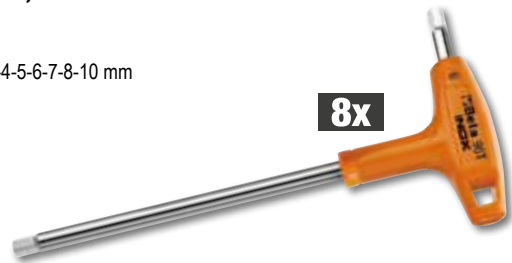

8x

000961954

1203INOX/D8

Set of 8 screwdrivers made of stainless steel

- 1290INOX ● 2,5x50-3x75-4x100-5,5x150-6,5x150 mm
- 1292INOX ⊕ PH0x60-PH1x80-PH2x100 mm



Beta *evox*

NEW

012030408

REELS



Each reel is fitted with a 180° swivel wall-mount bracket and an additional bracket for quick connection and disconnection from the wall-mount support.

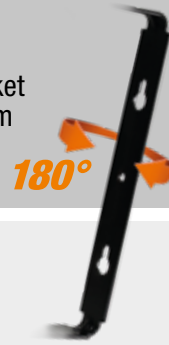

CABLE REEL

- Length of cable out of shell: 1 m
- Rack mechanism can be disabled to keep cable in traction

1842 15-H05/LED

018420821

Automatic cable reel with LED inspection lamp, 100-240Vac

- With 230/12V safety transformer
- H05VV-F 2x1.0 mm² cable



15 m



1845 15-H07

018450367

Automatic cable reel, with 3Gx2.5 mm² cable

- 3Gx2.5 mm² cable
- With thermal protection switch
- Max. power (rolled up): 2000W (230V-20°C)
- Max. power (unrolled): 3000W (230V-20°C)



15 m

1844 15-H05

Automatic cable reel, with 3Gx1.5 mm² cable

- 3Gx1.5 mm² cable
- With thermal protection switch
- Max. power (rolled up): 1500W (230V-20°C)
- Max. power (unrolled): 2500W (230V-20°C)



15 m

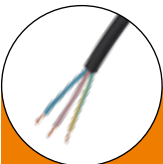

1844 15-H05

Automatic cable reel, with cable



1844 15-H05/SCK

Automatic cable reel, and SCHUKO type socket and plug



1844 15-H05/3SCK

Cable reel with 3 SCHUKO-type sockets and plug

NEW

1845EM/3

018450403

Automatic cable reel, with 3Gx2.5 mm² cable and TYPE 2 socket for charging EVs

- 3Gx2.5 mm² cable
- With thermal protection switch
- Supplied with a 1.5-m-long cable and a TYPE 2 socket
- Rack mechanism can be disabled to keep cable pulled
- Max. power: 3000W (230V-50Hz-16A)



7 m



NEW

1844 15-H05	018440315
1844 15-H05/SCK	018440316
1844 15-H05/3SCK	018440319

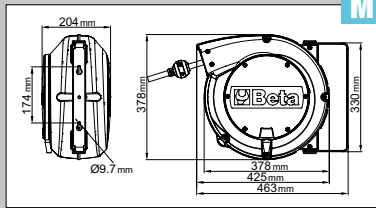
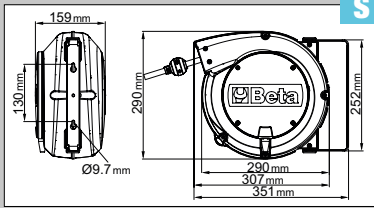
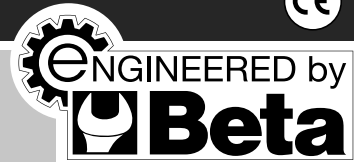

HOSE REEL

- Max. operating pressure: 15 bar
- Braided polyurethane hose
- Operating temperature range: -5 °C / +50 °C



1900S 8X10

019000080

Automatic spring hose reel with 8x12 mm cable

- Cable length 10 m



Ø GAS BSP 1/4"

1900M 8X15

019000085

Automatic spring hose reel with 8x12 mm cable

- Cable length 15 m



Ø GAS BSP 1/4"

1900M 10X15

019000115

Automatic spring hose reel with 10x14 mm cable

- Cable length 15 m



Ø GAS BSP 3/8"

1900M 12X15

019000125

Automatic spring hose reel with 12x16 mm cable

- Cable length 15 m



Ø GAS BSP 1/2"

1547/C6

3 kg **015470006**

Dummy ball bearing extractors

Bearings:
1547/1
6011-6014, 6206-6211, 6303-6308,
6403-6405

1547/2
6004-6010, 6200-6205, 6300-6304

- Quick, safe extraction



420x185x60 mm



1545/C5M

2,4 kg **015450011**

Puller 1542/1 with 5 extractors 1544



265x180x45 mm

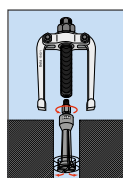

	A mm	C mm
1544/1	9+12	0,80
1544/2	13+17	1,15
1544/3	16+21	1,70
1544/4	20+25	1,65
1544/5	25+30	2,00



1430/S5

014300105

Set of 5 tapered extractors for broken screws and studs, made from hardened steel in case

M3-M18
1430/1-1430/2-1430/3
1430/4-1430/5



110x150x40 mm

1500N

Universal pullers with 2 sliding legs

- Special leg design, for automatic leg locking under loading conditions
- For both external and internal use
- Legs can be moved along crosspiece.

	A min+max mm	L mm	L1 mm	● mm	A1 mm	
1500N/0	18+65	70	100	15	110	015000600
1500N/1	23+70	100	130	17	130	015000601
1500N/2	23+100	100	130	17	160	015000602
1500N/3	35+140	150	190	20	230	015000603
1500N/4	35+190	150	190	20	280	015000604
1500N/5	43+250	205	295	27	360	015000605
1500N/6	43+320	205	295	27	430	015000606

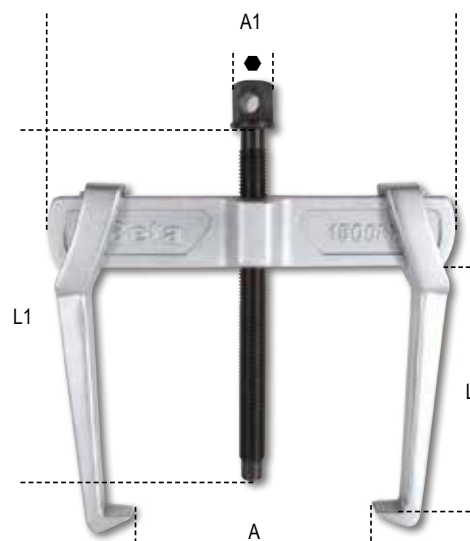

3027N HYDRAULIC PRESS WITH MOVING PISTON



Hydraulic bench press

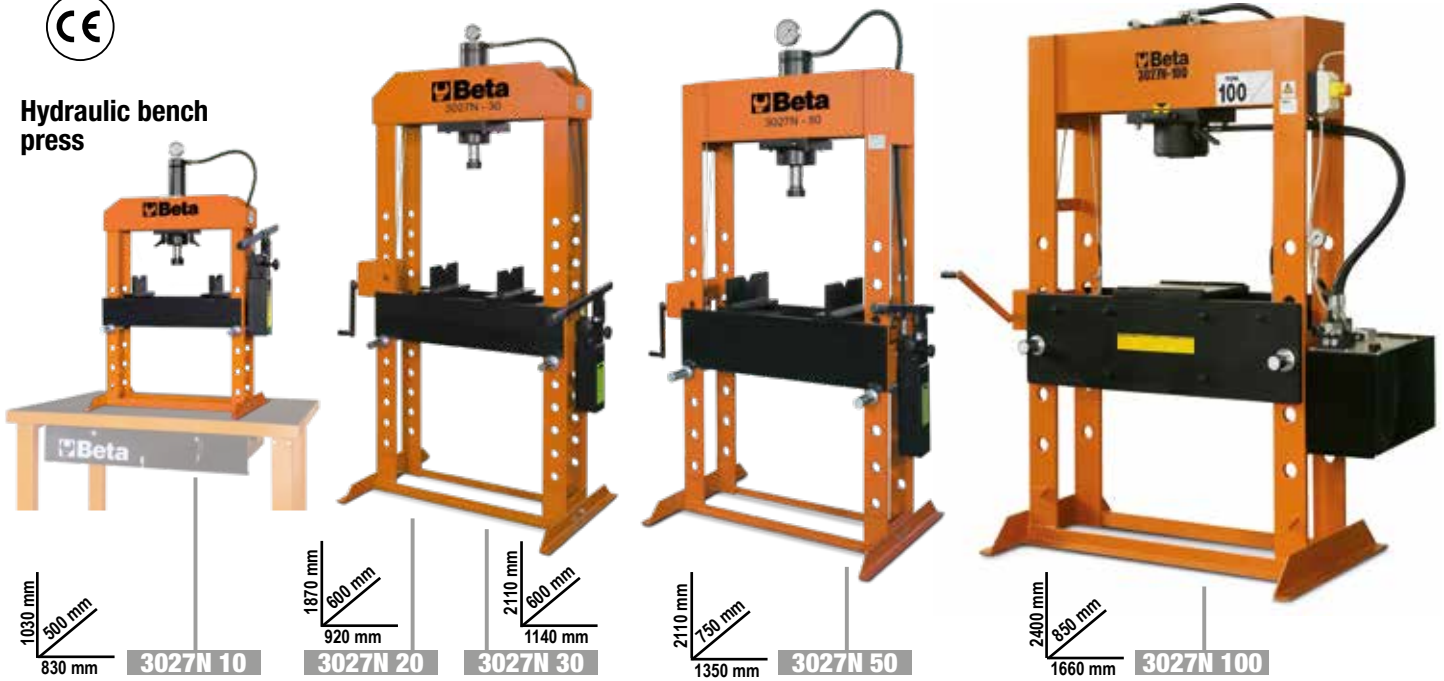

	kg	Code
3027N 10	100	030270101
3027N 20	130	030270102
3027N 30	230	030270103
3027N 50	350	030270105
3027N 100	1100	030270110

	3027N 10	3027N 20	3027N 30	3027N 50	3027N 100
Maximum capacity	10 t	20 t	30 t	50 t	100 t
Single speed pump	✓	✓	✓	✓	X
Moving piston	✓	✓	✓	✓	✓
Hydraulic safety in case of overloading	✓	✓	✓	✓	✓
Gauge	✓	✓	✓	✓	✓
Set of V-shaped prisms	✓	✓	✓	✓	✓
Hoist	X	X	✓	✓	✓

3025N 1,0

99 kg 030250110

Folding hydraulic crane with dual effect pump



- Maximum capacity: 1 t
- 4 loading positions: 300-600-800-1000 kg
- With load limiting valve and chrome-plated stand
- Controlled descent speed
- Nylon wheels
- Maximum height: 2420 mm



1889N

018890220

Steel handling and storage base for 2 200-l barrels

- Easy to carry with a fork lift truck or a pallet jack
- Support cannot be placed under any part
- Completely hot painted with epoxy powder, for high resistance to chemicals

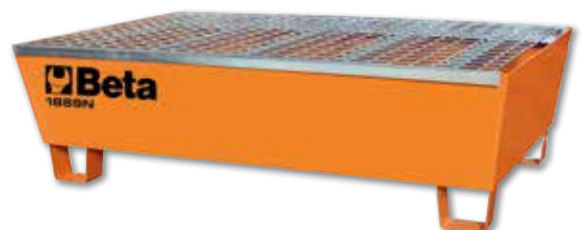

TANK CAPACITY: 235 l

1498H

Electronic multipurpose battery charger

Electronic battery chargers 1498H: innovation and technology made to work for professionals! Fitted with LCD displays and 3-colour LED indicators, they can be used with all types of batteries, both lead-acid and lithium. The electronic control card provides full protection against unexpected events. The 9 automatic charging steps ensure fast, efficient charging, with recovery and desulphation features.



- LCD display
- 3-light intensity LED
- Charging and charge maintenance
- Protection against reverse polarity, short-circuits, overheating, overloading, overtemperature
- Spark protection
- 9 charging steps
- Floating system
- Functions: battery recovery, battery test and desulphation
- Clamp holder
- Reclining fixing hook
- Supplied accessories: cable with clamps, cable with eyelets



1498H/4A	014980204
1498H/8A	014980208
1498H/16A	014980216
1498H/25A	014980225

	1498H/4A	1498H/8A	1498H/16A	1498H/25A
Power supply (1ph)	230 V - 50/60 Hz	230 V - 50/60 Hz	230 V - 50/60 Hz	230 V - 50/60 Hz
Charging current	1-4 A	2-8 A	4-16 A	6-24 A
Battery types	Pb - GEL - Ca/Ca - AGM - Start/Stop - Lithium (LiFePO4)			
Charging capacity	5-80Ah (LiFePO4 1-80Ah)	10-160Ah (LiFePO4 2-160Ah)	20-360Ah (LiFePO4 4-360Ah)	30-550Ah (LiFePO4 6-550Ah)
Maintenance capacity	5-120Ah (LiFePO4 1-120Ah)	10-250Ah (LiFePO4 2-250Ah)	20-550Ah (LiFePO4 4-550Ah)	30-800Ah (LiFePO4 6-800Ah)
Power supply (DC)	N/A	13.8V - 5A	13.8V - 12A	13.8V - 20A
Output voltage	6-12V	12-24V	12-24V	12-24V
Degree of protection	IP65		IP20	

1498PRO

Portable starter, Pro

- **Graphic display with ammeter and charging status indication**
- Charging via automatic electronic power supplier
- Charging via cigarette lighter socket
- Internal protection fuse
- Shoulder strap included
- Sealed lead-acid storage battery (AGM)



1498PRO/12

014980812

Portable starter, 12V, Pro

- For starting all GT and economy cars, 12V, petrol or diesel
- Pickup current: 3200A
- Battery capacity: 25 Ah

1498PRO/12-24

014980824

Portable starter, 12/24V, Pro

- For starting all vehicle types with 12V or 24V batteries
- Pickup current: 5000A 12V - 2500A 24V
- Battery capacity: 2 x 20 Ah

NEW

1498ULTRA

LITHIUM TECHNOLOGY



COMPACT, LIGHTWEIGHT AND POWERFUL, IT ALLOWS VEHICLES TO BE QUICKLY STARTED. THE LATEST-GENERATION MICROPROCESSOR PROVIDES FULL PROTECTION AGAINST:



**POLARITY REVERSAL
SHORT CIRCUITS
OVERLOADS
OVERTEMPERATURE**



1498ULTRA/12

014980960

Portable lithium starter, 12 V

Compact, lightweight and powerful, it allows vehicles to be quickly started, e.g. under critical conditions, based on 5000A pickup current. Designed and developed by Beta, it comes complete with comprehensive electronic protection, backlit display, USB-C socket for power bank function and high-performance LiFePO4 battery.

- Polarity reversal: 12 V
- Short circuits: 5000 A
- Overloads: 2500 A
- Overtemperature: 10000 mAh

1498ULTRA/12-24

014980970

Portable lithium starter, 12-24V

Compact, powerful and state-of-the-art, it is the ideal partner for the most demanding professionals: based on 10000 A peak power and 25 mm² cables, this starter provides high performance, which is also ideal for the flattest batteries and the toughest challenges.

- Polarity reversal: 12-24 V
- Short circuits: 10000 A (12V) /5000 A (24 V)
- Overloads: 5000 A (12V) /2500 A (24 V)
- Overtemperature: 2 x 10000 mAh

1498EL

Portable starter

- Charging via automatic electronic power supplier
- Charging via cigarette lighter socket
- Internal protection fuse
- Battery charging status LED indicator
- Shoulder strap included
- Sealed lead-acid storage battery (AGM)



1498EL/12

014980712

Portable starter, 12V

- For starting all GT and economy cars, 12V, petrol or diesel
- Pickup current: 1800A
- Battery capacity: 22 Ah

1498EL/12-24

014980724

Portable starter, 12/24V

- For starting all cars and commercial vehicles with 12V/24V batteries
- Corrente di spunto: 3600A 12V - 1800A 24V
- Capacità batteria: 2x 22 Ah

1498TB/12-24N

014980402

Digital battery tester, 12-24V, with built-in printer

- Allows the following to be tested: battery, alternator, starter and system
- Reverse polarity protector
- Fitted with software for connecting instrument to PC
- Backlit display
- Compact, shockproof frame
- 9 language software

Technical data:

- Applications: 12V and 24V batteries
- Operating range: 100-2000 CCA
- Reference standards: CCA,SAE,DIN,EN,IEC,JIS, MCA, GB, BCI, CA
- Supported batteries: PB, WET, GEL, AGM, AGM FLAT, EFB, SLI
- Voltmeter: 9V-30V
- Cable length: 1800 mm
- Supported languages: Italian, English, French, German, Spanish, Polish, Dutch, Hungarian, Portuguese
- Included accessories: USB cable, 3 printer paper rolls



1498BC/12

014980040

Multipurpose portable starter, 12V

Device protecting against polarity reversal, short-circuit, overcurrent, overcharge and overheating

Supplied with:

- Protective case
- Cable with starting clamps
- USB ports for charging electronic devices
- LED battery charge indicator
- USB and USB-C cable
- Mains power supply
- Multifunction LED torch

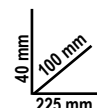

Starting current	600A
Pickup current	1500A
Battery type	4 cells LifePo4
Battery capacity	25000mAh

1497/C94

014970300

Assortment of 94 car testing connectors for use with main diagnostic tools

Assortment contents:

- 24 flat male terminals 0.6÷6 mm
- 12 round male terminals 1.6÷3.9 mm
- 24 flat female terminals 0.6÷6 mm
- 12 round female terminals 1.6÷3.9 mm
- 2 t-taps
- 2 potentiometers
- 2 warning lights
- 2 SRS connectors
- 2 alligator clips
- 2 acicular probes
- 2 prods
- 2 dual banana connectors
- 4 single banana connectors



430x390x100 mm

1497/C23

014970200

Assortment of 23 tools for releasing electrical connectors



440x250x70 mm

1760DGT

01760005

Digital automotive multimeter

Technical Data:

- RPM (tachometer):
For 2 and 4 cylinder engines
RPM4 600 - 4000 RPM
RPM4 600 - 12000 RPM (x10 RPM)
RPM2/DIS 300 - 4000 RPM
RPM2/DIS 300 - 6000 RPM (x10 RPM)
- Dwell angle: 4-8 CYL
- DC voltage: 400mV-4/40/400/1000V
- AC voltage: 4/40/400/700V
- DC current: 40/400mA-4/20A
- AC current: 40/400mA-4/20A
- Resistance: 400Ω-4/40/400kΩ-4/40MΩ
- Capacity: 40/400nF-4/40/100μF
- Frequency: 5/50/500Hz-50/500-10MHz
- Duty cycle: 0.1 % - 99.9%
- Pulse amplitude: 1 - 10ms
- Diode test: Test current 0.3mA
- Continuity: <150Ω - Test current <0.3mA
- Display: High-contrast, backlit 4-digit LCD
- Overvoltage: Category II 1000V
- Auto power off: 30 minutes
- Power supply: 1 9V battery (included)
- Inductive clamp (included)
- 2 tips (included)
- Soft cloth case (included)
- Operating manual



1760B

01760012

Digital multimeter

SPECIFICATIONS

- DC voltage: 200 mV-2/20/200/1000
- VAC voltage: 2-20/200/700VDC
- Current: 2/20/200 mA-20 AAC
- Current: 2/200 mA- 20 A
- Resistance:
200Ω - 2/20/200 kΩ - 2/20 MΩ
- Capacity: 2/20/200 nF - 2/200 μF
- Temperature:
-20° + 1000°C/ -4 °F ~ +2000°F
- Frequency: 20kHz
- Power supply: 1 9V battery (included)



1760PA/AC-DC

Amperometric clamp and digital multimeter

SPECIFICATIONS

- DC voltage: 0.1mV ÷ 600V
- AC voltage: 0.1mV ÷ 600V
- AC current: 0.01A ÷ 1000A
- DC current: 0.01A ÷ 1000A
- Resistance: 0.1Ω ÷ 40MΩ

- Capacity: 0.001nF ÷ 40 μF
- Frequency: 0.001kHz ÷ 4kHz
- Temperature: -40°C ÷ 1000 °C
-40°F ÷ 1832°F



01760000

1000 A



1760/IR500

Digital infrared thermometer with dual laser aiming system

TECHNICAL DATA

- Temperature range: -50 ÷ 500 °C (-22 ÷ +932 °F)
- Display resolution: 0.1 °C (0,1 °F)
- Emissivity: 0.1 ÷ 1 adjustable
- Accuracy: -50 °C ÷ +20 °C (+/- 3 °C);
20 ÷ 500 °C (+/-2% or 2 °C)
- Optical resolution (D:S): 12:1
- Auto power off: ca. 10 seconds
- Operating temperature: 0 °C ÷ 50 °C
- Storage temperature: -20 °C ÷ 60 °C
- Power supply: 1 9V battery



500 °C



017600350



1464CBD/N

014640301

Comprehensive adapter set for testing compression in petrol and diesel engines, with tester 1464T and 1464T/N

Makes it possible to connect to engine to test petrol and diesel compression with tester 1464T and 1464T/N

Contents:

- 8 dummy spark plugs with non-return valves
- 44 dummy glow plugs with non-return valves
- 1 adjustable universal dummy injector for cars, trucks, marine engines and agricultural machines
- 1 90° adapter, pressure release valve and connecting hose
- space accommodating tester 1464T in case

1464T/N ✓



510x410x140 mm

NEW

1464APD

014640100

Set for testing high pressure system in common rail diesel engines, for use with item 1464T and 1464T/N

Allows connection between high pressure pump and injector flute, to test common rail system pressure.

Set contents:

- high pressure hose set:
- fittings
- 2,000 bar sensor
- assortment of dummy regulators
- assortment of injector fuel fitting plugs

1464T/N ✓



Supplied hose sizes:

- T12x12-M1.5
- T12x14-M1.5
- T12x16-M1.5
- T12-M1.5

Bosch, Delphi, Denso and Siemens pressure regulators

510x415x130 mm

1464T/N

014640090

Digital pressure and compression tester

- Large digital display, backlit
- Rechargeable polymer lithium battery
- Complete with 80 bar sensor (for low pressure)
- Connection via cable free sensor
- Measurement and software update download via Wi-Fi
- Shockproof case
- For use in combination with kits 1464 for testing engine pressure and compression

Beta's digital tester, 1464T, can be used to measure numerous parameters in the automotive industry.

The 80 bar pressure sensor it is fitted with can be used to test pressure and compression in petrol and diesel engines as well as oil pressure, the low pressure common rail circuit, and perform several other tests. The internal software can be updated via Wi-Fi connection. The result of the measurements is displayed on the 8" touch screen. Data will be represented graphically or numerically, depending on the test that is being performed.



1464BP

014640200

Set of connectors for testing low pressure, for use with item 1464T and 1464T/N

Provide optimal measurements with the set of low pressure adapters: efficiency and lasting performance for your engine.

The quick connectors connected to tester 1464T/N make it possible to rapidly test fuel low pressure in diesel and petrol engines as well as AdBlue® and TDI pressure.

1464T/N ✓



510x415x130 mm

Technical data:

- Display: 8"
- Resolution: 800x840 px
- Processor: Dual core 240 MHz
- Internal memory: 32 Mb
- Software: 32-bits



1464PO

014640270

Set for testing oil pressure, for use with item 1464T and 1464T/N

Set contents:

- 10 engine oil pressure fittings
- 4 turbo oil pressure fittings
- 90° fitting
- Rubber extension with quick coupling



350x290x90 mm

1464APB

014640500

Set for testing high pressure system in FSI petrol engines, for use with item 1464T and 1464T/N

Comes with 200 bar sensor and connectors



240x210x50 mm

1464FAP

014640610

Set for testing diesel particulate filter (DPF) pressure, for use with item 1464T and 1464T/N

Supplied with:

- 500 mbar sensor
- 8 mm adaptor with quick coupling and T fitting
- 3-m-long RJ45 cable

Technical data:

- Pressure test: 0÷500 mbar
- Resolution: 1 mbar



240x210x50 mm

1464PT

014640550

Set for testing turbo pressure, for use with item 1464T and 1464T/N

Comes with sensor and connecting cable

Technical data:

Pressure test: 0÷3 bar
Resolution: 1 mba



240x210x50 mm

1464VD

014640570

Vacuum testing set, for use with item 1464T and 1464T/N

For measuring and storing maximum vacuum value.

Supplied with:

- 800 mbar sensor
- 6 and 8 mm adaptors
- 3-m-long RJ45 cable

Technical data:

- Vacuum test: 0÷800 mbar
- Resolution: 1 mbar
- Maximum value storage



240x210x50 mm

961N

009610030

Electronic videoscope with flexible, rotating probe

- TFT LCD 5" screen
- Supports SD cards
- Video and image recording
- 4 LEDs
- Power supply via USB port (built-in battery)
- Rotating probe
- High resolution

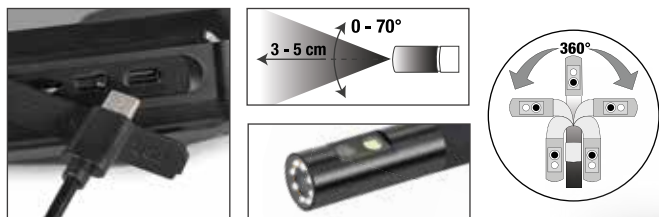

Discover the videoscope, 961N, your versatile partner for all jobs!

Based on the probe that can be rotated 360° and the double lit camera reaching the most inaccessible points has never been so easy. Defects and problems can be found easily and accurately. And with the new TFT LCD 5" display and outstanding resolution (1920x1080), you can enjoy sharp, bright images and videos, like never before. **Choose the videoscope, 961N, for uncompromised quality.**

Multi-purpose trolley

Can be used as a mobile workstation for diagnostic tools, laptops, testers and battery chargers

- Painted sheet metal frame: unparalleled firmness and sturdiness
- Ergonomic handle
- 2 fixed rear castors Ø 160 mm
- 2 steering front castors Ø 100 mm (one with brake)

2 central shelves with adjustable position and 1 fixed low shelf

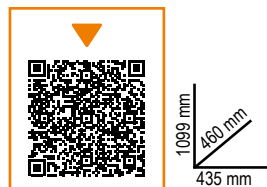

2-level top



Pull-out drawer for housing a mini keyboard



1 paper holder



2 useful side containers



4 useful side cable reels made of plastic

CA49-G **42 kg** **049000112**

Multi-purpose trolley with door, empty

CX49-G **40 kg** **049000102**

Multi-purpose trolley, empty

CB52-0

Gearbox/transmission trolley with liquid recovery system

Inclined plane and drain holes allow liquids to be recovered in collection tank

Fitted with:

- 4 swivel castors, including 2 with brakes
- Tool drawer
- Pull-out liquid collection tank; capacity: 7 l
- 2 shelves



60 kg **052000201**



1877

018770008

Exhausted oil drain unit, wheeled, with 90 l tank

- Level indicator
- Big diameter pan with breakwater grate; capacity: 12 l
- Pneumatic tank emptying through 1.8 m pipe
- Tool tray



1877A

018770080

Exhausted oil drain unit / vacuum cleaner, wheeled, with 90 l tank and pre-chamber

- Transparent pre-chamber: capacity 9.5 l
- Pneumatic tank emptying through 1.8 m pipe

Standard accessories:

- 1 hard probe, Ø 5x700 mm
- 1 flexible probe, Ø 5x700 mm
- 1 hard probe, Ø 6x600 mm
- 1 flexible probe, Ø 6x700 mm
- 1 flexible probe, Ø 7x700 mm
- 1 flexible probe, Ø 8x700 mm
- Adapters for VW, BMW, CITROËN



1756G

017560615

Diesel oil gun capacity: 1.5 l



Kit contents:

- 2 pipes with female quick couplings for connecting diesel oil pipes
- 2 male quick couplings, made of metal
- 1 cone-shaped adapter for rubber pipes

1756D

017560515

Suction gun, 1.5 l, made of polypropylene

- Double NBR gasket
- Operating temperature: +0 - +50 °C
- NOT suitable for fuel



1756V

017560504

Oil suction gun, 200 ml, made from polypropylene

- For transferring oil and brake fluid
- Operating temperature: +0 °C ÷ +50 °C
- Not suitable for fuel and flammable liquids
- Usable minimum oil density: lower than SAE30



1880

018800001

Manual oil barrel pump

- For oil
- Do not use with aqueous fluids, acid solvents, Diesel oil, petrol and the like
- Complete with barrel connection, telescopic tube and delivery spout
- For use with 60, 100 and 200 l barrels



1758B

017580030

Non-return funnel with quick couplings

Particularly suitable for VAG cars

NON-RETURN



14825N

014820110

Quick coupler swivel pliers for fuel pipes, with articulated jaws



L mm
260

1488

Oil-filter wrench with double chain



	Ø mm	
1488	60÷110	014880001
1488L	60÷160	014880050

1490

Strap wrenches for oil filters

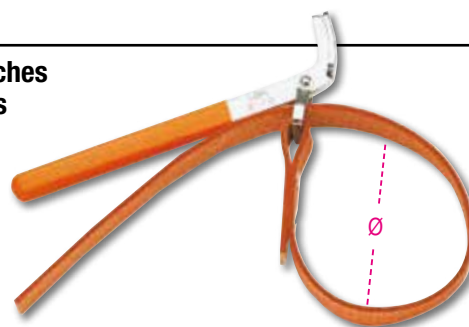

	Ø max mm	
1490/1	160	014900001
1490/2	240	014900002

1488/1

014880010

Oil-filter wrench with thin double chain

1/2"

Ø mm
60÷110

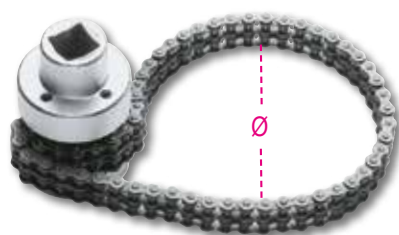

1491

014910001

Adjustable oil filter wrench

Ø mm
65÷110



1493/C30

014930000

Set of 28 oil filter wrenches

- For tightening and loosening oil filters
- 1/2" female drive
- In plastic case

530x400x110 mm



1493PF (Purflux)
66/6 - 76/12 - 76/30 - 86/18
93/36 - 93/45 - 96/18 - 108/18

Includes 1 adjustable oil filter wrench
Ø 65÷120 mm

1852R1750/N

018520176

Portable induction heater

- Heats and loosens bolts, hubs and bearings without using flames.
- Allows any type of ferromagnetic metal to be heated.



480x370x130 mm

NEW COIL ADDED TO THE CASE

Benefits:

- 1 Time saving: quick, extremely accurate heating
- 2 Fire safety: does not produce flames, maximum operator safety
- 3 Functional: can be used with one hand, and coils can be easily interchanged

Fields of Application:

- Automotive industry
- Industrial maintenance
- Aviation industry
- Naval industry
- Petrochemical industry

Technical data:

- Input voltage: 230V AC, 50/60 Hz
- Input current: max. 7,5A
- Power: max. 1.75 kW



One contact coil	
Two front attachable coils, Ø 19 and 26 mm, for loosening nuts	
One flat coil for heating surfaces	
One flexible coil, 800 mm long	

NEW

1852RL3700

018520370

Portable induction heater, 3.7 kW, with coolant

The liquid-cooled portable induction heater is the ideal solution for the quick, efficient heating of ferromagnetic and conductive materials. The 2-m-long inductor results in remarkable versatility, catering to different work requirements.

Benefits

- Time-saving: quick, extremely accurate heating
- Fire safety: does not produce flames, maximum operator safety
- Functional: can be used with one hand, and coils can be easily interchanged.

Fields of application:

- Automotive
- Garages/vehicle repair
- Railway and naval industry
- Heating and piping installation
- General maintenance

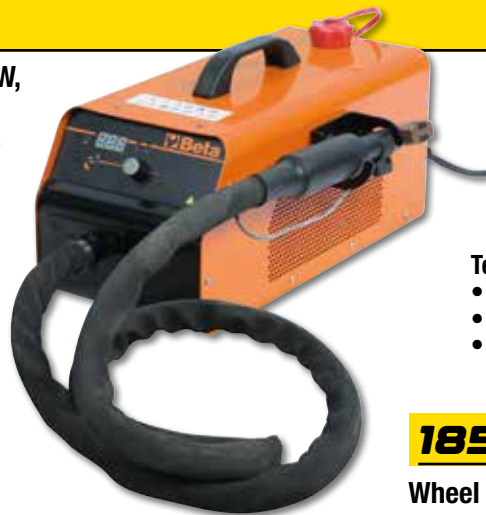

240 mm
200 mm
440 mm



Technical data:

- Input voltage: U1 230 V 50/60 Hz
- Input current: I1 16 A
- Max. power: P2max 2400 W

1852RL-S/DR

018520551

Wheel nut coils



NEW

960VTC

2,3 kg

009600261

Leakage tester for petrol engine cylinders

After compressed air has been introduced into cylinder, gauge will allow it to be tested for compression leaks

Supplied couplers:

M10 - M12 - M14 - M14 long



373x295x70,6 mm



960KC-M8/M9/M10

2,3 kg **009600801**

Assortment of tools for removing broken or damaged glow plugs



FOR SPARK PLUGS WITH THREADS M8-M9-M10

380x290x50 mm

1759HD/3

6,5 kg **017590063**

Cooling system seal testing and circuit filling tools

Make it possible to check circuit (pipes, joints, pumps, radiators) for leaks under pressure and quickly fill circuit, avoiding air bubble formation



600x500x140 mm

960KPC

2,8 kg **009600780**

1/4" Reversible impulse extractor with adjustable torque for glow plugs

- Pneumatic extractor with adjustable torque and special sockets allow jammed glow plugs to be unscrewed, thereby minimizing damage risk
- 5 1/4" impact sockets, long series, specially designed for glow plugs: 8-9-10-11-12 mm, 2 extensions and 1 articulated joint
- 4 adjustable driving torques: 10-20-30-40 Nm
- Right-hand and left-hand adjustment



420x185x60 mm

1884

018840010

Oil filler tool for manual and automatic gearboxes and differentials

- Complete with 12 adaptors for direct connection
- Fitted with nonreturn valve for leakage-free oil filling
- Delivery: 70 cc per pump shot
- Tank capacity: 7.5 l
- Maximum permissible oil viscosity: SAE 140



12 ADAPTORS

FORD	AT-101
UNIVERSAL (Bmw, Honda, Nissan...)	AT-102
VW-AUDI	AT-103
VW-AUDI-PORSCHE	AT-104
VW-AUDI-MINI COOPER	AT-105
MERCEDES	AT-106
DSG	AT-107
VW-AUDI CVT	AT-108
VOLVO	AT-109
TOYOTA-LEXUS	AT-110
SKODA	AT-111
VW Passat/Tiguan <2007	AT-112



1895

Ultrasonic cleaning tank
with special degas function

- Ultrasonic cleaning relies on fluid heating to effectively clean spare parts and metal pieces in general (carburetors, valves etc.)
- Digital display for temperature and cleaning time selection
- Two cleaning modes: "soft" and "normal"
- For normal cleaning, just use water at a temperature of 50/60 °C
- For more accurate cleaning, add non-foaming detergent solutions specific for ultrasonic tanks
- Using the degas mode speeds up air release throughout the tank, thereby improving ultrasonic cleaning efficiency



1895 157

1895 6

018950060

Ultrasonic cleaning tank 6 l

1895 27

018950270

Ultrasonic cleaning tank 27 l

1895 13

018950130

Ultrasonic cleaning tank 13 l

1895 157

018950357

Ultrasonic cleaning tank 157 l

	1895 6	1895 13	1895 27	1895 157
Tank capacity	6 litres	13 litres	27 litres	157 litres
Drain tap	✓	✓	✓	✓
Power	150 Watt	300 Watt	500 Watt	2160 Watt
Heating power	300 Watt	400 Watt	500 Watt	5000 Watt
Temperature range	0÷80 °C	0÷80 °C	0÷80 °C	30÷110 °C
Cleaning time range	0-99 minutes	0-99 minutes	0-99 minutes	0-59 minutes
Frequency	40 kHz	40 kHz	40 kHz	28 kHz - 40 kHz
Power supply	220/230V	220/230V	220/230V	220/380V
Dimensions	330x180x310 mm	350x325x320 mm	530x330x380 mm	840x640x750 mm
Tank size	300x155x150 mm	325x235x145 mm	500x300x200 mm	700x500x450 mm



1471M/C22

014710101

Pneumatic tool for pushing back and rotating right and left disc brake pistons with accessories

- Automatic jack
- Thrust: 150 kg
- Operating pressure 5÷8 bar

350x310x85 mm



1467

014670001

Brake fluid extractor

Pressure: min 5 bar, max 11.5 bar



1467LF/2

15 kg 014670099

Electric instrument for brake fluid replacement

Allows brake fluid to be easily and quickly replaced on vehicle

- Automatically stops when tank is empty, thereby preventing air from being let in
- Maximum tank volume: 20 l
- Operating pressure: 0.4÷3.5 bar
- Power supply: 230V

Supplied with:

- Brake oil recovery tank
- 1 standard cap E20



“PULSATING EFFECT”



3009

030090001

Wheel lifter

Maximum lifting capacity: 550 kg

- 4 pivoting rollers
- Roller width: 200 mm
- For wheels up to 240 mm in width



IDEAL FOR:

- **LOADING DAMAGED CARS ONTO TOW TRUCKS**
- **CAR REPAIR GARAGES**
- **MOVING CARS IN SHOWROOMS**

1949GPA

019490018

Tyre inflator

- Pressure release feature
- Pressure measurement feature



1949DGT/2

019490021

Digital tyre inflator

- 4 units of measurement, bar/psi/kpa/kgf
- Backlit LCD display
- Resolution: 0.05 bar
- Self-power off after 1.5 minutes



1768

017680010

Aluminium footboard

200 kg



SURFACE COATED WITH NON-SLIP MATERIAL

L mm	L1 mm	H mm
960	300	475



3035

30 kg

030350100

Tyre trolley

- For easily transporting tyres up to 980 mm in diameter
- The sturdy frame allows tyres to be handled without bearing the weight physically
- Can be used as a top by locking position horizontally
- 2 castors Ø 260 mm
- 2 castors Ø 125 mm
- Maximum transportable height: 1.60 m
- Maximum carrying capacity: 200 kg
- Forks can be adjusted in 2 positions:
first position:
maximum opening 880 mm
second position:
maximum opening 980 mm



1550U

015500010

Pneumatic shock absorber removal tool for cars, SUVs and commercial vehicles

- Upper universal hold system that allows all left/right-hand spring diameters to be compressed with one upper adaptable plate
- Active safety system on spring: safety hook and 3 locking valves allow spring to be properly positioned/seated, maintaining such position throughout compression. If spring is not positioned properly, system will stop machine.
- Protective "Full Body" Grille
- Supplied with 2 lower forks for diameters 78-205 mm
- Maximum thrust: 2 tons (10 bars) - 1.6 tons (8 bars) - 1.2 tons (6 bars)
- Spring compression stroke: 335 mm



MAXIMUM THRUST 2 TONS (10 BAR)

1670 mm
610 mm
825 mm

1567

015670001

Lever for removing wishbone heads and shock absorbers from pillar

One operator can position lever effortlessly and proceed with disassembly

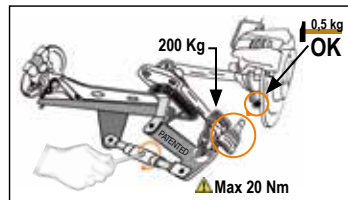
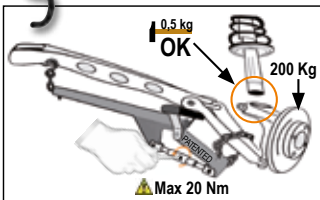

1365/K13

33 kg **013650013**

Oil pressure pump, 10 t, and bodywork accessories kit in handy trolley

Kit contents:

- oil pressure pump, 10 t, with 1.5-m-long hose, 1/2" coupling
- piston
- wing opening pliers; capacity: 500 kg
- baseplate, 150x90 mm
- L-shaped base, 50x50 mm
- 4-point punch
- round, knurled punch, Ø 50 mm
- wedge-shaped punch, 43 mm
- 240-mm-long extension
- 450-mm-long extension
- 475-mm-long extension
- rubber head
- male-to-male coupling for installing accessories



900x420x180 mm

1366SH

23 kg **013660400**

Multifunction bodywork spotter

- Microprocessor for managing welding parameters
- Contact and manual welding cycle start
- Automatic spot welding time setting function
- Supplied with quick coupling gun and 2.2-m-long ground cable

Accessory kit contents:

- extractor hammer
- three-pointed washer head
- 10 three-pointed washers
- carbon electrode
- squashing electrode

Power supply	230V
50% power	2.5 KVA
Power peak	13 KVA
Amp output	2850 (2%) A
Max. Amp output	3200 A

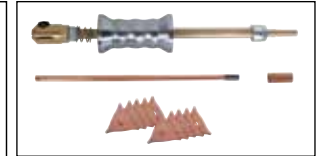

2254K

022540101

Reusable seat, steering wheel and gear knob protector



2254F

022540150



Car front protector

Allows front part of vehicle to be protected, while leaving openings for headlights and radiator

1766

017660001

Double suction lifter



1479

014790001

Trim pin remover



1874 50

018740050

Solid and fluid vacuum cleaner, 50 l, stainless steel drum

- Two-stage by-pass motor
- Voltage: 220/240 V
- Frequency: 50/60 Hz
- Max. power: 1350 W
- Airflow rate: 55 l/sec.
- Max. suction power: 240 mbar
- Max. drum capacity: 50 l, made of stainless steel
- Acoustic emissions: <63 dB(A)
- Cable length: 6 m
- Trolley for accessories



FILTERING SYSTEMS

- 1 filter paper bag
- 1 surface filter cartridge 5200 cm², 12 µm nom.
- 1 anti-foam filter PPI 45/PPI 30

STANDARD ACCESSORIES, Ø 45 mm

- 1 corrugated hose with ergonomic handle
- 2 stainless steel extension tubes
- 1 industrial brush frame
- 1 industrial section for carpets
- 1 industrial section with fluid collection hoses
- 1 flat nozzle

1479/B27

014790407

Kit of 27 nylon tools for removing pins and working on plastics and seals, hangable



2250-0

022500011

Heavy duty swivel creeper seat with tray

- Round swivel seat
- Height can be adjusted through a gas piston mechanism (410-530 mm)
- 2 tote/tool trays, one being vertically adjustable
- 5 pivoting castors



1898/C

018980940

Wheeled sprayer, 25 l

- Dual function: spraying and foaming
- Painted steel tank
- Stainless steel nozzle
- Anti-twisting hose
- Tank pressure gauge
- Tank level indicator



Technical data:

- Tank capacity: 25 l
- Supply hose length: 5 m
- Maximum working pressure: 4-5 bar
- Nozzle length: 0.65 m
- Maximum tank pressure: 8 bar

3002

7,7 kg

030020001

Creeper and seat

- Steel frame
- PVC lining with upholstery
- Easily convertible into a creeper or a seat



3029/2T

030290020
Lowered hydraulic jack, 2 t, with 4 wheels

- Quick approach pedal
- Steel frame and nylon wheels
- Minimum height: 75 mm



H min-Max mm	L mm	L1 mm
75÷500	720	290



2 t

L1

3029L/2T

030290120
Long, lowered hydraulic jack, 2 t

- Makes it possible to work on vehicles with a reduced height from the ground and internal lifting point.
- Controlled descent speed
 - Quick approach pedal
 - Nylon wheels



H min-Max mm	L mm	L1 mm
75÷520	930	295



2 t

L1

3033E/3T

030330130
Hydraulic jack, 3 t

- Controlled descent speed
- Nylon wheels



H min-Max mm	L mm	L1 mm
95÷515	700	370



3 t

L1

3030/2T

030300020
Lowered hydraulic car jack, 2 t with 6 wheels

- Car jack can be easily handled on uneven, irregular floors
- Dual front tilting wheels made of plastic material (PTFE)
- Pedal allows easy approach



H min-Max mm	L mm	L1 mm
85÷520	860	400



2 t

L1

3029AL/1,5T

030290015
Aluminium hydraulic jack, 1.5 t

With a weight of no more than 15 kg and a capacity of 1.5 t, this tool means a perfect combination of performance and convenience, to allow you to deal with the most unexpected and critical situations: rescue operations, e.g. on race tracks, or emergency services.



H min-Max mm	L mm	L1 mm
76÷355	550	240



NYLON TRANSPORTATION BAG INCLUDED



1,5 t

L1

3030H/2T

030300220

High-lift hydraulic jack, 2 t, with 6 wheels

Makes it possible to work on vehicles that are high from the ground and have a long shock absorber travel

- Controlled descent speed
- Quick approach pedal
- Nylon wheels



H min-Max mm	L mm	L1 mm
85÷780	1010	300



2 t



3065/40-20T

030650200

Air hydraulic jack, 40/20 tons

- Suitable for use on heavy vehicles
- Functional and easy to handle, for transportation on mobile repair shops as well
- Automatic piston return
- Two descent valves with under load speed control



H min-Max mm	L mm	L1 mm
150÷300	525	300



40-20 t



3067/60-15T

030670120

Air hydraulic jack, 60-30-15 t

- Automatic piston return
- Two descent valves with under load speed control
- Supplied with two extensions, 70 and 120 mm long
- Include due prolunghe da 70 e 120 mm
- Power supply pressure: 8-10 bar
- Air consumption: 600 l/min



H min-Max mm	L mm	L1 mm
120÷255	660	250



60-30-15 t



3040C

Rear motorcycle stand, adjustable

- Matt black lacquer
- 4 thermoplastic rubber wheels
- Includes V-shaped sliders, pair
- Includes L-shaped sliders, pair

030400002



3043C

Motorcycle stand with left single arm

- Matt black lacquer
- 4 thermoplastic rubber wheels
- Optional pin

030430002



3023

030230050

Pit and under bridge jack with screw adjustment

MAXIMUM CARRYING CAPACITY: 350 KG

H min-Max mm	Ø mm
1350÷2030	300



3011T

Hydraulic bottle jack



	C max kg	H min+max mm	
3011T 2	2000	174÷369	030110020
3011T 3,5	3000	170÷366	030110035
3011T 5	6000	203÷467	030110050
3011T 10	10000	220÷484	030110100
3011T 15	15000	230÷497	030110150
3011T 20	20000	245÷521	030110200
3011T 32	32000	260÷420	030110320
3011T 50	50000	280÷450	030110500

3010T

Jack stands, pair

	C max kg	H min+max mm	
3010T 2	2000	280÷425	030100002
3010T 3	3000	285÷430	030100003
3010T 6	6000	400÷580	030100006
3010T 10	10000	471÷735	030100010



3010T 2
3010T 3
3010T 6

3010H

Heavy-duty jack stands

	C max kg	H min+max mm	L x L1 mm	kg	
3010H631-T15	15,000	445÷631	300x300	22,5	030100150
3010H1077-T15	15,000	645÷1077	300x300	30	030100165



3010V

Heavy-duty jack stands, screw adjustable

	C max kg	H min+max mm	L / L1 mm	
3010V600-T20	20,000	410÷600	330x330	030100200
3010V1090-T20	20,000	665÷1090	460x460	030100220



3014SAR

030140360

Folding engine stand

- Easy to fold up, for significantly increased compactness
- Allows 360° rotation of engine or gear
- Provides unparalleled safety and stability during jobs

MAXIMUM CAPACITY: 450 KG



3026

Hydraulic pit and under bridge jack



3026 0,3

030260003

24,7 kg

3026 0,5

030260005

31 kg

3026 1,0

030260010

37,8 kg



3026 0,3 3026 0,5 3026 1,0

Maximum capacity	300 kg	500 kg	1000 kg
Pedal pump	✓	✓	✓
Minimum height	1120 ÷ 1970 mm	1140 ÷ 1990 mm	1140 ÷ 1990 mm
Load limiting valve	✓	✓	✓

8143



Hand chain blocks

- Professional model, complies with EN13157 standard, made of first-rate materials
- Designed to lift heavy loads quickly and safely



TÜV EN 13157

	WLL t	L m	kg	
8143 0,5T	0,5	3	9,2	081430005
8143 1T	1	3	11,7	081430010
8143 2T	2	3	19,5	081430020
8143 3T	3	3	19,5	081430030

8146



Lever hoists

- Professional model, complies with EN13157 standard, easy to install and use
- Automatic brake with double pawl system for optimized safety
- Swivel hook with safety latch.

AVAILABLE CERTIFICATES

- CE Declaration of Conformity
- Test report UNI EN10204 type 2.2
- Manufacturer's Certificate



TÜV EN 13157

	WLL t	L m	kg	
8146 0,75T	0,75	1,5	6,7	081460008
8146 1,5T	1,50	1,5	11,2	081460015

8146C



Lever hoist, compact

	WLL t	L m	kg	
8146C 0,25T	0,25	1,5	2,5	081460002

NEW

AUTOMOTIVE KIT

4 kits, 4 comprehensive solutions for your work.
Discover the new automotive kits designed for every job.

3033/KVA-1

030330901

Automotive kit with hydraulic jack item 3033E/3T, C51 trolley, swivel creeper seat 2251N and reversible impact wrench item 1927P/K3 with 3 impact sockets

C51



1927P/K3



3033E/3T



2251N



PROMO

3033/KVA-2

030330902

Automotive kit with hydraulic jack item 3033E/3T, creeper/seat 3002 and reversible impact wrench item 1927P/K3 with 3 impact sockets.

1927P/K3



3002



3033E/3T



PROMO

NEW

TIRE KIT

1927OLS/KVA

019271091

Tire kit with Oil-less impact wrench item 1927OLS, torque wrench item 666/20, tyre inflator 1949GPA and sockets item 720LC/C3

1927OLS



666/20

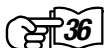

PROMO



720LC/C3



1949GPA



1927C/KVP

019271082

Tire kit with item 1927C torque wrench, item 666/20 and sockets item 720LC/C3, 720MRC, 720FRD, 720RNG

1927C

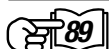

666/20

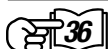

720LC/C3



720MRC



720FRD



720RNG



PROMO

OIL
LESS

THE REVOLUTIONARY IMPACT WRENCH THAT DOES NOT REQUIRE LUBRICATION



The impact wrench, 1927OLS, fully designed, developed and engineered by Beta Utensili, relies on the OIL-LESS system, a brand-new innovation in the pneumatic tool industry: it allows the impact wrench to operate without having to be periodically lubricated with oil, thus ensuring increased durability and high performance.



1927OLS

2,5 kg

019270010

1/2" OIL-LESS reversible impact wrench, body made from aluminium alloy

The OIL-LESS impact wrench stands out for high torque transmission – that is, 1750 Nm –, which makes it ideal for any application.

- No lubrication required
- Double hammer impulse device

- 1** Balanced and powerful, with unparalleled service life
- 2** Three power adjustable screwing positions
- 3** Vibration free handle
- 4** Exhaust through handle

Free speed	8.000 rpm
Max. torque	1.750 Nm
Bolt capacity	Cl 8.8 M24●36 mm
Bolt capacity	Cl 12.9 M20●30 mm
Air inlet	1/4" GAS
Operating pressure	6,2 bar
Internal hose size (Ø)	10 mm
Mean air consumption	198 l/min

PATENT PENDING



1927P

2 kg

019270008

1/2" Reversible impact wrench

- Double hammer impulse device
- Lightweight and well-balanced for enhanced ease of use
- Reversible lever
- Three power adjustable screwing positions
- Exhaust through handle
- Vibration-damping handle



1750 Nm

Free speed	rpm	7.500
Impulse device		Double hammer
Max. torque	Nm	1750
Bolt capacity	Cl 8.8	M24●36 mm
Bolt capacity	Cl 12.9	M20●30 mm
Air inlet	GAS	1/4"
Operating pressure	bar	6,2
Internal hose size (Ø)	mm	10
Mean air consumption	l/min	290

1927C

2,4 kg 019270006

12" Reversible impact wrench, made from composite material

- Double hammer impulse device
- Lightweight and well-balanced, for enhanced ease of use
- Reverse control lever
- Three power adjustable screwing positions
- Exhaust through handle
- Vibration-damping handle

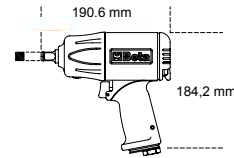

Free speed	rpm	9.000
Impulse device		Double hammer
Max. torque	Nm	950
Bolt capacity	Cl 8.8	M22●34 mm
Bolt capacity	Cl 12.9	M18●27 mm
Air inlet	GAS	1/4"
Operating pressure	bar	6,2
Internal hose size (Ø)	mm	10
Mean air consumption	l/min	125

1927E

2,4 kg 019270005

12" Reversible impact wrench, made from composite material

- Double hammer impulse device
- Reverse control knob
- Three power adjustable screwing positions
- Exhaust through handle
- Vibration-damping handle

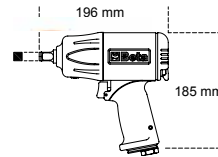

Free speed	rpm	7.000
Impulse device		Double hammer
Max. torque	Nm	750
Bolt capacity	Cl 8.8	M22●36 mm
Bolt capacity	Cl 12.9	M18●30 mm
Air inlet	GAS	1/4"
Operating pressure	bar	6,2
Internal hose size (Ø)	mm	10
Mean air consumption	l/min	140

1927XM

1,3 kg 019270030

12" Compact reversible impact wrench

- Single hammer impulse device
- Amazingly compact and powerful
- One-hand reverse button
- Three power adjustable screwing positions
- Exhaust through handle
- Balancing hook



SUPER COMPACT

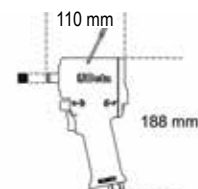

Free speed	rpm	10.000
Impulse device		Single hammer
Max. torque	Nm	770
Bolt capacity	Cl 8.8	M22●34 mm
Bolt capacity	Cl 12.9	M18●27 mm
Air inlet	GAS	1/4"
Operating pressure	bar	6,2
Internal hose size (Ø)	mm	10
Mean air consumption	l/min	122

1928XM

2,9 kg **019280030**

3/4" Compact reversible impact wrench

- Double hammer impulse device
- Amazingly compact and powerful
- One-hand reverse button
- Three power adjustable screwing positions
- Exhaust through handle



1600 Nm
ULTRA COMPACT AND POWERFUL



Free speed	rpm	4.800
Impulse device		Double hammer
Max. torque	Nm	1600
Bolt capacity	Cl 8.8	M27●41 mm
Bolt capacity	Cl 12.9	M24●36 mm
Air inlet	GAS	3/8"
Operating pressure	bar	6,2
Internal hose size (Ø)	mm	10
Mean air consumption	l/min	175

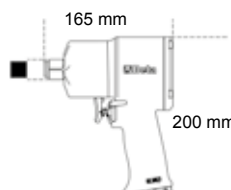

1928P

3,7 kg **019280006**

3/4" Reversible impact wrench, made from composite material

- Double hammer impulse device
- Lightweight and well-balanced for enhanced ease of use
- Reversible lever
- Three power adjustable screwing positions
- Exhaust through handle
- Vibration-damping handle



2100 Nm
ULTRA COMPACT AND POWERFUL

Free speed	rpm	5.000
Impulse device		Double hammer
Max. torque	Nm	2100
Bolt capacity	Cl 8.8	M30●46 mm
Bolt capacity	Cl 12.9	M27●41 mm
Air inlet	GAS	3/8"
Operating pressure	bar	6,2
Internal hose size (Ø)	mm	10
Mean air consumption	l/min	221

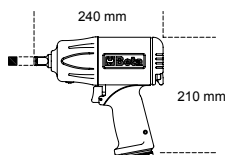

1930LH

7,1 kg **019300030**

1" Reversible impact wrench

- Double hammer impulse device
- 210 mm (8.3") long anvil
- New 70-degree angled handle design to relieve stress and fatigue on the operator's wrists
- Auxiliary side handle
- 3 power adjustable screwing/unscrewing positions
- Lower exhaust
- Excellent weight/power ratio



Free speed	rpm	6.000
Impulse device		Double hammer
Max. torque	Nm	2441
Bolt capacity	Cl 8.8	M36●55 mm
Bolt capacity	Cl 12.9	M30●46 mm

Air inlet	GAS	1/2"
Operating pressure	bar	6,2
Internal hose size (Ø)	mm	13
Mean air consumption	l/min	280

1922P3

1,5 kg 019220013

12" Reversible air impact ratchets

- Double rocking dog impulse device
- Easy tightening: the impact mechanism system eliminates wrist twisting at end of screwing and shortens operating time
- Compact and powerful: maximum torque is significantly higher than maximum torque as achieved with a conventional ratchet
- Ergonomic rubber handle

136 Nm

**HIGH TORQUE
WITHOUT AFFECTING WRIST**



292 mm

Free speed	rpm	600
Maximum torque	Nm	136
Bolt capacity	Cl 8.8	M12●18 mm
Bolt capacity	Cl 12.9	M10●16 mm
Air inlet	GAS	1/4"
Operating pressure	bar	6,2
Internal hose size (Ø)	mm	10
Mean air consumption	l/min	113

720ME/C8

12" 8 impact socket drivers for hexagon screws



○ 5-6-8-10-12-14-17-19 mm



270x120x45 mm



007200525

720/C24

007200904

12" Set of 24 impact sockets



420x185x60 mm



	720	10-12-13-14-15-16-17-18 19-21-22-24-27-30-32 mm
	720L	13-17-19-21-22-24 mm
	720LC	17-19-21 mm

720LC/C3

007200653

12" 3 impact sockets for wheel nuts, with polymeric inserts



○ 17-19-21 mm



148x132x44 mm



728/C10

5,7 kg 007280910

3/4" 10 impact sockets



○ 17-19-22-24-27-30
32-36-41-46 mm



275x120x65 mm



720/C12

007200912

12" 12 impact sockets



○ 10-11-12-13-14-17-19
22-24-27-30-32 mm

195x80x55 mm



1933

380 g **019330001**

Die grinder

- Collect chuck, Ø 3 mm and 6 mm

Free speed	rpm	25.000
Chuck capacity	mm	3-6
Power	kW	0,20
Air inlet	GAS	1/4"
Operating pressure	bar	6,2
Internal hose size (Ø)	mm	10
Mean air consumption	l/min	230



1933L

670 g **019330015**

Long spindle die grinder

- Collect chuck, Ø 3 mm and 6 mm

Free speed	rpm	25.000
Chuck capacity	mm	3-6
Power	kW	0,20
Air inlet	GAS	1/4"
Operating pressure	bar	6,2
Internal hose size (Ø)	mm	10
Mean air consumption	l/min	370



1936

Angle grinder

- Extremely compact and handy
- Air governor for automatically controlling top speed
- Right-hand/left-hand auxiliary handle
- Spindle lock button
- Accessory for quickly changing discs
- Safety cap can be quickly adjusted in nine different positions through quick release
- Rear exhaust

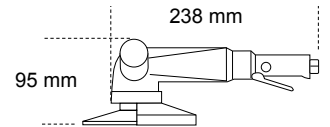

		kg
1936/4A	019360024	1,8
1936/5A	019360025	1,9

		1936/4A	1936/5A
Free speed	rpm	11.000	10.000
Grinding disc size	mm	115	125
Power	kW	0,66	0,66
Spindle thread	M	14	14
Air inlet	GAS	1/4"	1/4"
Working pressure	bar	6,2	6,2
Internal hose size (Ø)	mm	10	10
Mean air consumption	l/min	390	390

1942A

550 g **019420000**

Air saw

- Powerful and handy
- Designed for cutting bodies, exhaust pipes and silencers, aluminium and plastic
- Complete with rubber handle, PVC exhaust pipe and air-feeding hose
- Rear exhaust

Strokes per minute		10.000
Stroke length	mm	10
Air inlet	GAS	1/4"
Operating pressure	bar	6,2
Internal hose size (Ø)	mm	8
Mean air consumption	l/min	75



1946

Air riveter

- Supplied with interchangeable nozzles, 2.4 - 3.2 - 4.0 - 4.8 mm long, a safety nail container and a balancing hook

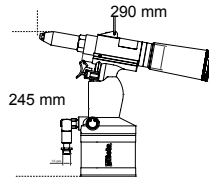

1,5 kg 019460001



Material/Riveter	2,4	3,2	4	4,8
Copper	✓	✓	✓	✓
Aluminium	✓	✓	✓	✓
Steel	✓	✓	✓	
Stainless steel	✓	✓	✓	

Traction power	8.000 N
Stroke length	14 mm
Maximum rivet capacity	Ø aluminium 4,8 mm
Air inlet	1/4" GAS
Operating pressure	6,2 bar
Internal hose size (Ø)	6 mm
Mean air consumption	1,2 l/cycles

1946C 7,8

Automatic air suction riveter

- Professional air riveter for use with 2.4 - 3.2 - 4.0 - 4.8 mm long steel, stainless steel, aluminium and copper rivets
- Pointed cone-shaped spout
- Powerful and handy, with handle made of composite material
- Complete with safety nail container and oil gun

1,8 kg 019460008

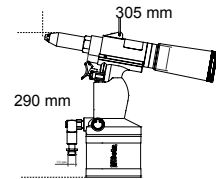

Material/Riveter	2,4	3,2	4	4,8
Copper	✓	✓	✓	✓
Aluminium	✓	✓	✓	✓
Steel	✓	✓	✓	
Stainless steel	✓	✓	✓	

Traction power	16.900 N
Stroke length	22,5 mm
Maximum rivet capacity	Ø aluminium 7,8 mm
Air inlet	1/4" GAS
Operating pressure	6,2 bar
Internal hose size (Ø)	10 mm
Mean air consumption	4,9 l/cycles

1949F2

019490028

Progressive blow gun

- Made from hard-wearing, shockproof, scratchproof, thermally insulated composite plastic material
- Special valve and lever allow circuit to be progressively opened, thus optimizing air flow
- Tip with safety plastic cone for safe handling when not in use



Ø 1/4" GAS BSP

Brass threaded insert	GAS	1/4"
Operating pressure	bar	4-8
Maximum operating pressure	bar	12
Operating temperature	°C	-20+70

1948

019480001

Engraving pen

- Its tungsten carbide bit allows such materials as steel, stainless steel, aluminium, glass, stone and ceramic to be marked



Strokes per minute	3.500 + 3.800
Maximum hardness	60 HRC
Air inlet	1/4" GAS
Working pressure	6,2 bar
Mean air consumption	50 l/min
Weight	150 g

RENEGADE

THE SAFETY FOOTWEAR RANGE



EN ISO 20345 2022



7340VA

495 g

Scarpe RENEGADE in tessuto mesh ad alta traspirazione con allacciatura rapida ATOP



S1PS FO SR HRO

Sizes available: from 37 to 48
📏 from 073400537 to 073400548

7340G

495 g

RENEGADE mesh fabric shoe, highly breathable, with traditional lacing



S1PS FO SR HRO

Sizes available: from 37 to 48
📏 from 073400637 to 073400648

7341V

495 g

RENEGADE woven fabric, hard-wearing and breathable, green details, with traditional lacing



S1PS FO SR HRO

Sizes available: from 37 to 48
📏 from 073410537 to 073410548

7341Y

495 g

RENEGADE woven fabric shoe, hard-wearing and breathable, yellow details, with traditional lacing



S1PS FO SR HRO

Sizes available: from 37 to 48
📏 from 073410637 to 073410648

7342N

500 g

RENEGADE microfibre shoe, water-repellent, with traditional lacing



S3S FO SR HRO

Sizes available: from 37 to 48
📏 from 073420537 to 073420548

7343N

510 g

RENEGADE microfibre ankle shoe, water-repellent, with traditional lacing



S3S FO SR HRO

Sizes available: from 37 to 48
📏 from 073430537 to 073430548

FitEvolution

THE PATENTED SYSTEM BETA



FIT4YOU



7272V

550 g

FitEvolution woven fabric shoe,
hard-wearing and highly breathable



S1 PS FO SR ESD

Sizes available: from 37 to 48
from 072720137 to 072720148

7270Y

550 g

FitEvolution mesh fabric shoe,
highly breathable



S1 PS FO SR ESD

Sizes available: from 37 to 48
from 072700137 to 072700148

7271V

550 g

FitEvolution suede shoe, perforated



S1 PS FO SR ESD

Sizes available: from 37 to 48
from 072710137 to 072710148

7273G

590 g

FitEvolution nubuck shoe,
water-repellent



S3 S FO SR ESD

Sizes available: from 37 to 48
from 072730137 to 072730148

7274G

650 g

FitEvolution nubuck ankle shoe,
water-repellent



S3 S FO SR ESD

Sizes available: from 37 to 48
from 072740237 to 072740248

7275N

590 g

FitEvolution nubuck shoe,
microfibre shoe, water-repellent



S3 S FO SR ESD

Sizes available: from 37 to 48
from 072750237 to 072750248

Beta
O-Gravity



- EVA outsole with durable nitrile rubber tread
- Heel stability support
- EVA midsole

- Composite fibre penetration-proof insole
- Composite toe cap

7352B

450 g

O-Gravity mesh fabric shoe, highly breathable, with TPU inserts

- Stretch slip-on collar



EN ISO 20345:2022 + A1:2024

S1PL FO SR HRO

Sizes available: from 38 to 48
from 073520138 to 073520148

7352G

450 g

O-Gravity ultralightweight mesh fabric shoe, highly breathable

- Traditional lacing



EN ISO 20345 2011



S1P HRO SRC ESD



Sizes available: from 38 to 48
from 073520338 to 073520348

7354N

460 g

O-Gravity lightweight mesh fabric shoe, waterproof

- Stretch slip-on collar



EN ISO 20345:2022 + A1:2024

S3L FO SR HRO

Sizes available: from 38 to 48
from 073540038 to 073540048

7356G

460 g

O-Gravity shoe, ultralightweight, made of water-repellent microfibre

- Stretch slip-on collar



EN ISO 20345:2022 + A1:2024

S3L FO SR HRO

Sizes available: from 38 to 48
from 073560038 to 073560048

7372B

450 g

O-Gravity woven fabric shoe, ultralightweight, hard-wearing and ultrabreathable

- Traditional lacing



EN ISO 20345 2011

S1P HRO SRC



Sizes available: from 38 to 46
from 073720038 to 073720046

7352LG

390 g

O-Gravity ultralight mesh fabric shoe

- Stretch slip-on collar



EN ISO 20345:2022 + A1:2024

S1PL FO SR HRO

Sizes available: from 34 to 42
from 073520234 to 073520242

ACTIVE



- Composite toe cap
- Composite fibre penetration-proof insole

7320NA

550 g

Nubuck shoe, water-repellent, with anti-abrasion reinforcement in toe cap area



EN ISO 20345:2022 + A1:2024

S3L FO SR

Sizes available: from 35 to 48
from 073200535 to 073200548

7316NG

510 g

Mesh and suede shoe, highly breathable, with heel stability support



EN ISO 20345 2011

S1P SRC ESD



Sizes available: from 35 to 48
from 073160635 to 073160648

7321NA

570 g

Nubuck shoe, water-repellent, with quick opening system and anti abrasion reinforcement in toe cap area



EN ISO 20345:2022 + A1:2024

QUICK OPENING SYSTEM

S3L FO SR

Sizes available: from 35 to 48
from 073210535 to 073210548

7322SA

570 g

Fabric shoe, highly resistant to abrasion



EN ISO 20345:2022 + A1:2024

S3 SRC

Sizes available: from 35 to 48
from 073220435 to 073220448

7317NA

550 g

Suede shoe, perforated, with microfibre reinforcement in heel area



EN ISO 20345:2022 + A1:2024

S1PL FO SR

Sizes available: from 35 to 48
from 073170135 to 073170148

7214G

500 g

Action nubuck shoe, water-repellent, with anti-abrasion insert in toe cap area



S3 SRC ESD

Sizes available: from 35 to 48
from 072140235 to 072140248

FLEX



BASIC



- Steel toe cap
- Steel penetration proof insole

7241NC

Leather safety shoe, water-repellent



S3 FO SR

Sizes available: from 35 to 48
 from 072411635 to 072411648

7243NC

Leather ankle shoe, water-repellent, with quick opening system



QUICK OPENING SYSTEM

S3 FO SR RS

Sizes available: from 35 to 48
 from 072431635 to 072431648

7246NB

Suede shoe, perforated



S1P FO SR

Sizes available: from 35 to 48
 from 072461635 to 072461648

7248NB

Suede ankle shoe



QUICK OPENING SYSTEM

S1P FO SR RS

Sizes available: from 35 to 48
 from 072481635 to 072481648

7247NB

Leather safety sandal



S1P FO SR

Sizes available: from 35 to 48
 from 072470635 to 072470648

7245NB

Leather ankle shoe, water-repellent, with quick opening system and front protection with strap closure



QUICK OPENING SYSTEM

S3 FO SR RS

Sizes available: from 35 to 48
 from 072451635 to 072451648

NEW

BASIC PLUS

- Composite toe cap
- Composite fibre penetration proof insole



7200BP

Suede shoe with highly breathable mesh inserts



S1PS FO SR

Sizes available: from 35 to 48
 from 072000635 to 072000648

7201BP

Suede sandal with strap closure



S1PS FO SR

Sizes available: from 35 to 48
 from 072010635 to 072010648

7202BP

Leather shoe, smooth-finished, water-repellent



S3S FO SR

Sizes available: from 35 to 48
 from 072020635 to 072020648

7203BP

Leather ankle shoe, smooth-finished, water-repellent, with quick opening system



QUICK OPENING SYSTEM

S3S FO SR RS

Sizes available: from 35 to 48
 from 072030635 to 072030648



QUICK OPENING SYSTEM

7204BP

Leather ankle shoe, smooth-finished, water-repellent, with quick opening system, front protection and strap closure. Hard-wearing rubber outsole.

S3S FO SR HRO RS

Sizes available: from 35 to 48
 from 072040635 to 072040648

NEW

TOP LINE
HIGH PERFORMANCE



7342N
Renegade  94

7569NG

3-in-1 jacket, with outer jacket and removable inner vest:

- **Outer shell** in 100% polyester with waterproof, windproof, breathable TPU membrane (resistance to water columns up to 8,000 mm - breathability 3,000 mvp)
- **Inner vest** in 100% nylon and 100% polyester padding, 100 g/m², with detachable hood
- **Black with anthracite grey inserts**



	XS	S	M	L	XL	2XL	3XL
	075690000	075690001	075690002	075690003	075690004	075690005	075690006

7565NG

Sweatshirt, long-zipped

- 60% cotton, 40% polyester, 280 g/m²
- Stretch sleeve bottoms and waist
- **Black with anthracite grey inserts**



	XS	S	M	L	XL	2XL	3XL
	075650400	075650401	075650402	075650403	075650404	075650405	075650406

7570NG

Stretch work trousers, multipocket style

- 94% polyester, 6% spandex, 140 g/m²,
- Reinforced pockets, stretch waist
- **Anthracite grey, with black inserts**
- Slim fit



	XS 46	S 48	M 50	L 52	XL 54	2XL 56	3XL 58
	075700000	075700001	075700002	075700003	075700004	075700005	075700006

7571NG

Stretch work Bermuda shorts, multipocket style

- 94% polyester, 6% spandex, 140 g/m²,
- Reinforced pockets, stretch waist
- **Anthracite grey, with black inserts**
- Slim fit



	XS 46	S 48	M 50	L 52	XL 54	2XL 56	3XL 58
	075710000	075710001	075710002	075710003	075710004	075710005	075710006

7643G



Sweatshirt, short-zipped

- 80% cotton, 20% polyester, 280 g/m²
- Anthracite/light grey



	XS	S	M	L	XL	2XL	3XL
	076430000	076430001	076430002	076430003	076430004	076430005	076430006

7820SG



Stretch work trousers, multipocket style, lightweight

- 39% cotton, 61% polyester, in mechanical stretch ripstop fabric, 170 g/m²
- Grey



	XS 46	S 48	M 50	L 52	XL 54	2XL 56	3XL 58
	078200100	078200101	078200102	078200103	078200104	078200105	078200106

7821SG



Stretch work Bermuda shorts, multipocket style, lightweight

- 39% cotton, 61% polyester, in mechanical stretch ripstop fabric, 170 g/m²
- Grey



	XS 46	S 48	M 50	L 52	XL 54	2XL 56	3XL 58
	078210100	078210101	078210102	078210103	078210104	078210105	078210106



7340VA
Renegade 94

7552

Three-button work polo shirt, made from cotton, 200 g/m²

7552G
Melange grey

7552N
Black

7552BL
Blue



100% COTTON

	XS	S	M	L	XL	2XL	3XL
7552BL	075520300	075520301	075520302	075520303	075520304	075520305	075520306
7552G	075520400	075520401	075520402	075520403	075520404	075520405	075520406
7552N	075520500	075520501	075520502	075520503	075520504	075520505	075520506

7548T

T-shirt with modern print

• 100% cotton, 150 g/m², black



	XS	S	M	L	XL	2XL	3XL
7548T	075480700	075480701	075480702	075480703	075480704	075480705	075480706

NEW

7548D

T-shirt with graffiti style print

• 100% cotton, 150 g/m², black



	XS	S	M	L	XL	2XL	3XL
7548D	075480600	075480601	075480602	075480603	075480604	075480605	075480606

NEW

7528

Stretch work jeans trousers

• 98% denim cotton, 2% stretch fabric



Jeans CE

7529

Stretch work bermuda jeans shorts

• 98% denim cotton, 2% stretch fabric



Jeans CE

	XS 46	S 48	M 50	L 52	XL 54	2XL 56	3XL 58
7528	075280046	075280048	075280050	075280052	075280054	075280056	075280058

	XS 46	S 48	M 50	L 52	XL 54	2XL 56	3XL 58
7529	075290046	075290048	075290050	075290052	075290054	075290056	075290058



7246NB
Basic 98

EASY LIGHT

7867G

Sleeveless work jacket, lightweight in T/C twill, 180 g/m²

- 65% polyester, 35% cotton, 180 g/m²
- Grey



	XS	S	M	L	XL	2XL	3XL	4XL	5XL
	078670800	078670801	078670802	078670803	078670804	078670805	078670806	078670807	078670808

7860

Work trousers, lightweight in T/C twill, 180 g/m²

- 65% polyester, 35% cotton; 180 g/m²
- T/C ripstop insets and knee pads
- Strap "Oxford" snap loop



Grey

7861

Work bermuda shorts, lightweight, in T/C twill, 180 g/m²

- 65% polyester, 35% cotton; 180 g/m²



Blue

	XS 46	S 48	M 50	L 52	XL 54	2XL 56	3XL 58	4XL 60	5XL 62
7860B	078600700	078600701	078600702	078600703	078600704	078600705	078600706	078600707	078600708
7860G	078600800	078600801	078600802	078600803	078600804	078600805	078600806	078600807	078600808

	XS 46	S 48	M 50	L 52	XL 54	2XL 56	3XL 58	4XL 60	5XL 62
7861B	078610700	078610701	078610702	078610703	078610704	078610705	078610706	078610707	078610708
7861G	078610800	078610801	078610802	078610803	078610804	078610805	078610806	078610807	078610808



Blue

Grey

7865G

Work overalls, lightweight in T/C twill, 180 g/m²

- 65% polyester, 35% cotton
- Oxford inserts
- Grey





	XS 46	S 48	M 50	L 52	XL 54	2XL 56	3XL 58	4XL 60	5XL 62
	078650800	078650801	078650802	078650803	078650804	078650805	078650806	078650807	078650808

Cotton  

7937MG

Sleeveless work jacket

- 97% cotton, 3% stretch fabric, 220 g/m²
- Grey



	XS	S	M	L	XL	2XL	3XL
	079370400	079370401	079370402	079370403	079370404	079370405	079370406



7930MG

Work trousers, multipocket style

- 97% cotton, 3% stretch fabric, 220 g/m²
- Stretch waistband
- Grey



	XS 46	S 48	M 50	L 52	XL 54	2XL 56	3XL 58
	079300400	079300401	079300402	079300403	079300404	079300405	079300406



7931MG

Work bermuda shorts

- 97% cotton, 3% stretch fabric, 220 g/m²
- Stretch waistband
- Grey



	XS 46	S 48	M 50	L 52	XL 54	2XL 56	3XL 58
	079310400	079310401	079310402	079310403	079310404	079310405	079310406



7935MG

Work overalls

- 97% cotton, 3% stretch fabric, 220 g/m²
- Grey

	XS 46	S 48	M 50	L 52	XL 54	2XL 56	3XL 58
	079350400	079350401	079350402	079350403	079350404	079350405	079350406



7340G
Renegade  94

9563U

095630020

Office armchair, ergonomic

- Back height: 97 cm
- Seat dimensions: 50 cm x 53 cm
- Overall chair height: 133-144 cm
- Base: 35 cm (leg length) x 49 cm (height)



9563G

095630050

Office armchairs, for guests

- Back height: 60 cm
- Seat dimensions: 45 cm x 51 cm
- Overall chair height: 110-120 cm
- Base: 28 cm (leg length) x 50-60 cm (height)



9526F

095260005

Mini fridge, energy efficiency class F, capacity 63 l, black

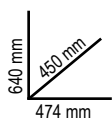

9566K

095660500

Furnishing set of 1 table and 3 vertically adjustable stools



9574

Work gloves, with stretch-elastic cuffs, reinforced thumbs and index fingers, made from touchscreen capable synthetic leather



	M	L	XL	2XL
9574B	095740102	095740103	095740104	095740105
95740	095740202	095740203	095740204	095740205

9525WB

095251032

Baseball cap with curved visor, white

9528C

095280100

Football, PU-coated, size 5

- Circumference: 68-70 cm
- Panels: 12
- Weight: 410-430 g
- Recommended pressure: 6-8 lbs/ 0.41-0.55 bar/ 6-8 psi





2025 MOT02
WORLD
CHAMPIONSHIP

CELESTINO VIETTI

ALONSO LÓPEZ



998016318



8

Beta Utensili S.p.A.

via Volta, 18 | 20845 Sovico (MB) - tel +39 039 20771 | www.beta-tools.com